



联系我们 / Contact Us

公司名称：苏州为山环境技术有限公司

Suzhou Weishans Climate Technologies Co.,Ltd

公司官网 / Web:www.weishans.com

地址：江苏省苏州市相城区黄埭镇咏春科技园

Address: Yongchun Science and Technology Park, Huangdai Town, Xiangcheng District, Suzhou City, Jiangsu Province

联系人Contact：王先生Mr.Wang13771888067，李先生Mr.Li15995875226



王先生 Mr.Wang

李先生 Mr.Li

高效涡旋压缩机

High Energy Efficiency Scroll Compressor

冷冻冷藏应用产品手册

Product Manual For Low & Middle Temperature Application

苏州为山环境技术有限公司
Suzhou Weishans Climate Technologies Co.,Ltd

免责声明
技术数据在印刷前已经校对过，印刷之后有再更新的可能。如有对某一参数确认的需求，请联系苏州为山环境技术有限公司。为山对参数中可能存在的差错概不承担任何责任，为山之保留自行改变其产品而不预先通知的权利。

Disclaimer
Our technical data have been checked before printing, but it is possible for data to be updated after printing. If you need to confirm a certain parameter, please contact Suzhou Weishans Climate Technology Co., Ltd. Weishans will not take any responsibilities for any possible errors in the parameters and reserve the right to change its products without prior notice.

为山者

积土成山，事当有为不为

为山者，当以九仞为目标，坚韧前行

居谷不弃，据高无傲，以余力尽余志

为山者，当持仁心，聚仁人志士以作为

仁德宽厚，虚怀若谷，度己度人，度可度之人

为山者智而不乱智，谋而不全谋

为山者实为治军，将即将，身先士卒，令必行，士必勤勇，功当巨赏

为山者胜于人，乃心胜于人，非物胜于人也

为山者，虽积跬步箕土，乃成伟山

WEISHANS

To build mountain with small amounts of earth, You would select what to do and what not to do.

To be WEISHANS, You should have a high goal, go forward no matter what difficulty to meet, No give up when you low,

No pride when you high, Do what you can do for the capable goal.

To be WEISHANS, You should have a heart like god, Collect kind and upright men to do something right, kind god feeling to others , mind breadth, sublime oneself and others ,and sublime the men who will sublime.

To be WEISHANS, should be smart but only smart on the right direction, and have astuteness on the right place.

To be WEISHANS, Just like build an army, General should be exactly like a leader with active and positive Behavior, order must have good result and active feedback, soldiers must be active to order and work hard, great reward for great job.

To be WEISHANS, They defeat others, They are so strong in mind not on the treasure.

To be WEISHANS, Even with small steps to reach peak , Even collect small earth to build great mountain.

目录Catalog

公司简介 <i>About us</i>	01
产品特点 <i>About Product</i>	04
关键技术及创新 <i>Characters and Advantages</i>	05
命名规则 <i>Nomenclature</i>	07
应用范围 <i>Application Range</i>	08
技术参数 <i>Specification</i>	09
制冷量 <i>Cooling Capacity</i>	17
外形尺寸 <i>Dimensional Information</i>	49

苏州为山之环境技术有限公司

Suzhou Weishans Climate Technologies Co., Ltd

坐落于苏州市相城区，是致力于开发节能环保产品的技术型企业。公司专注涡旋式制冷压缩机核心技术的研发，并不断突破创新。公司获得专利合计 35 件：其中发明专利 12 件，实用新型 22 件，软著 1 件；授权发明专利 2 件，实用新型专利 21 件，软著 1 件。在此基础上结合设计团队常年积累的丰富经验，研发了 2 ~ 25 匹全封闭系列涡旋式制冷压缩机。

is located at Xiangcheng district in Suzhou. It is a technical company devoted to develop energy conservation and environment protection products. Our company has been devoting to key technology of scroll refrigeration compressors and keeps making progresses on innovation. We have obtained a total of 35 patents: 12 Patents for invention, 22 for utility model and 1 for software; 2 patents for authorized invention, 21 patents for utility model and 1 for Software. The design team with the rich experience has developed 2~25HP hermetic scroll refrigeration compressors.

公司引入先进的涡旋式制冷压缩机自动化生产线以及进口高精度检测和加工设备，从硬件上保证了产品的一致性。公司注重质量管理体系建设，从初期就结合具体生产实践引入相关管理体系，将体系融入到公司的管理运营当中。公司秉承以人为本的理念，引进人才，不断激发员工的积极性和创造性，持续创新，不断提高生产效率和运营效率。目前已具备年生产 10 万台涡旋制冷压缩机的组装生产能力，是国内少数几家拥有该核心技术的企业。

The company has introduced advanced automatic production line and high-precision inspection and machining equipment to ensure product consistency from the hardware. Our company pays much attention to the quality management system development. We apply related management system to our production and operation at the beginning. We adhere to people-oriented concept and bring in talented employees. We keep inspiring the employees' activity and creativity and we keep innovating to continuously increase the production and operation efficiency. At present, we have the assembly capacity to produce 100,000 scroll refrigeration compressors annually, and it is one of the few domestic enterprises with this key technology.

“为山”商标是公司自有品牌，并通过了国家商标局认证。

"Weishan" trademark is our company's own brand and has passed the certification of the National Trademark Office.

公司产品通过了 CCC、CE 等认证，获得相城区科技领军人才称号，“为山”涡旋压缩机获得第八届中国制冷北极熊创新奖、第三届国际制冷“工匠精神企业奖”等荣誉称号。

Our products have passed CCC, CE certification. Weishans won the honorary title of Xiangcheng District Science and Technology Leading Talent. "Weishan" scroll compressors won the honorary titles such as the 8th China Refrigeration Exhibition "Polar Bear Innovation Award" and the 3rd International Refrigeration Exhibition "Artisan Spirit Enterprise Award".

www.weishans.com



OUR VISION

企业愿景

为山之遵循“求精不求巧，求本不求华”的产品理念，把“为山”打造成国内外知名品牌。

WE AIM TO MAKE "WEISHAN" THE FIRST-CLASS INTERNATIONAL BRAND. WE ALWAYS FOLLOW THE THINKING "TO ACHIEVE PERFECTION WITHOUT INGENUITY, SEEKING FOR ORIGIN WITHOUT REFINEMENT."

OUR MISSION

企业使命

以“九仞”为目标，坚韧前行；居谷不弃，据高无傲！

"JIUREN" IS OUR AIM. WE WILL MOVE FORWARD TOUGHLY. WE WILL NEVER GIVE UP EVEN IN DOWNS AND NEVER BE ARROGANT WHEN IN UPS.

SERVICE AIM

服务宗旨

顾客第一、品质第一、服务第一、持续改进、回报社会

CUSTOMERS FIRST, QUALITY FIRST, SERVICE FIRST, KEEPING IMPROVING, REPAYING SOCIETY

Build a Nine-ten Mountain
Forge Ahead

为山九仞 砥砺前行



ABOUT PRODUCT 产品特点

“为山”牌涡旋压缩机性能优良，突出的特点有：

1. 国产替代：拥有自主知识产权，且与国外知名企业的同等技术水平的产品具有良好的互换性。
2. 重点开发的中高功率范围12匹及以上的全封闭压缩机新产品，获得良好的市场应用口碑。
3. 针对不同的冷媒设计多种涡旋盘，适用范围广，WW系列压缩机在烘干机组上冷凝温度最高可达85摄氏度。
4. 能效比高，入围北极熊创新产品奖前三甲，是节能机组产品。

"Weishan" brand scroll compressors have excellent performance, and the outstanding features are as below:

1. *Localization substitution: independent intellectual property rights; good interchangeability with products of the same technical level as well-known foreign companies.*
2. *Stress-developed ≥ 12 HP hermetic compressors in the medium and high power range and get good market application reputation.*
3. *The products are designed with multiple scrolls for different refrigerants and have a wide application range. The condensing temperature of WW series can reach 85°C on the drying unit.*
4. *The products have high energy efficiency ratio are selected in the top three of the Polar Bear Innovative Product Award and are the energy-saving units.*

关键技术及创新

Characters and Advantages

关键技术及创新 CHARACTERS AND ADVANTAGES

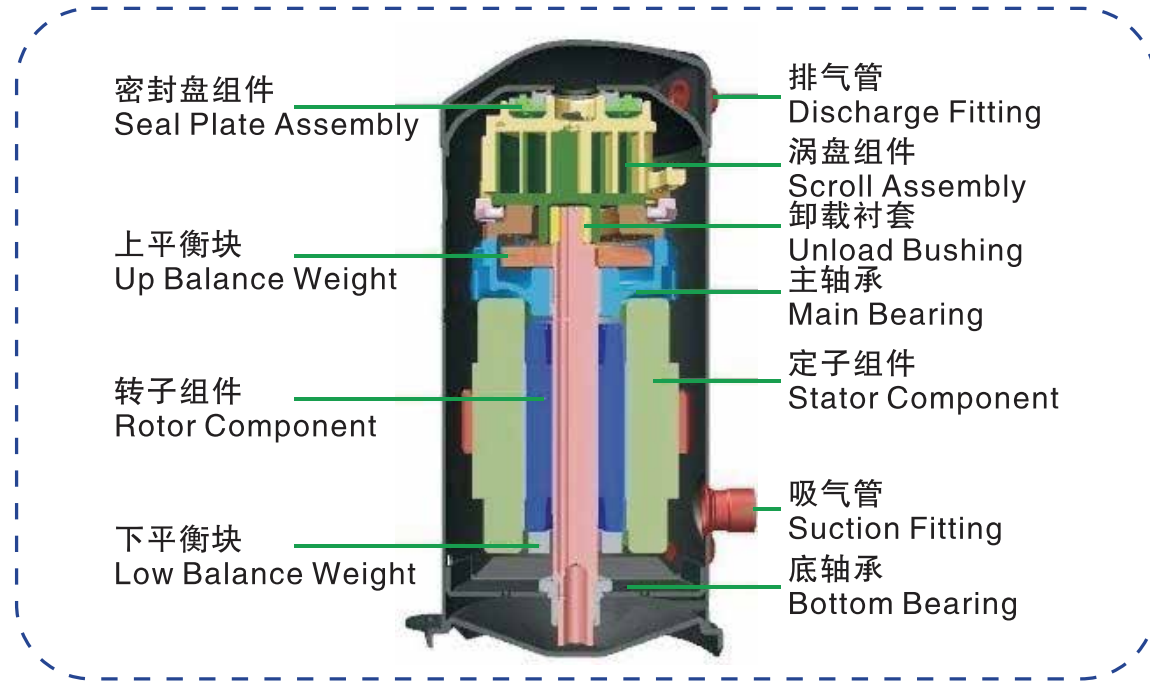

关键技术及创新

Characters and Advantages

关键技术及创新 CHARACTERS AND ADVANTAGES

为山之的涡旋压缩机为热泵，空调，冷水机及冷冻冷藏等应用提供了出众的解决方案，涡旋压缩机是高可靠性，高能效比，紧凑性系统设计的理想选择。为山系列涡旋压缩机可提供2~25HP的产品，其适用的制冷剂包括R410A, R22, R407C, R134a等

Weishans' scroll compression technology provide an outstanding solution for Heat pump, air conditioner, chiller and refrigeration applicaiton. Scroll compressors are an ideal choice with high reliability, high EER and compact system design. The scroll compressors of Weishan

series can provide 2HP~25HP products, the applicable refrigerants include R410A, R22,R407C, R134a ETC.

制冷量数据 Capacity Data

本样本所列压缩机制冷量数据, 电源频率50Hz (电机同步转速2900rpm)。当压缩机在60Hz频率 (电机转速3500rpm) 运行时, 制冷量以及输入功率相应约增加20%。压缩机不宜在应用范围外使用。

The capacity data of scroll compressors listed in this catalogue, power frequency is 50 Hz (Synchronous speed of motor 2900 rpm). When the compressors are operated with 60Hz (the speed of motor 3500 rpm), the capacity and input power are correspondingly increased about 20%. The compressors should not be used beyond the application range.

Cooling capacity data of compressor listed in this sample, power frequency: 50Hz(synchronous motor speed: 2900rpm)

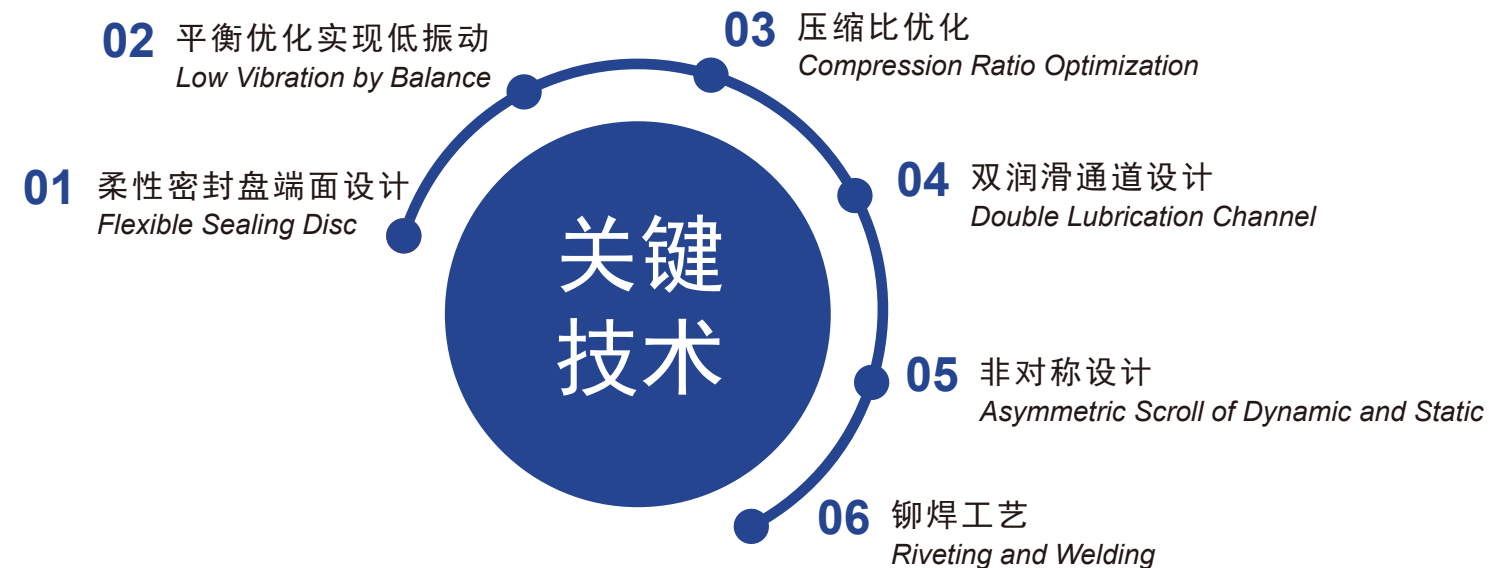

命名规则 Nomenclature

命名规则 NOMENCLATURE

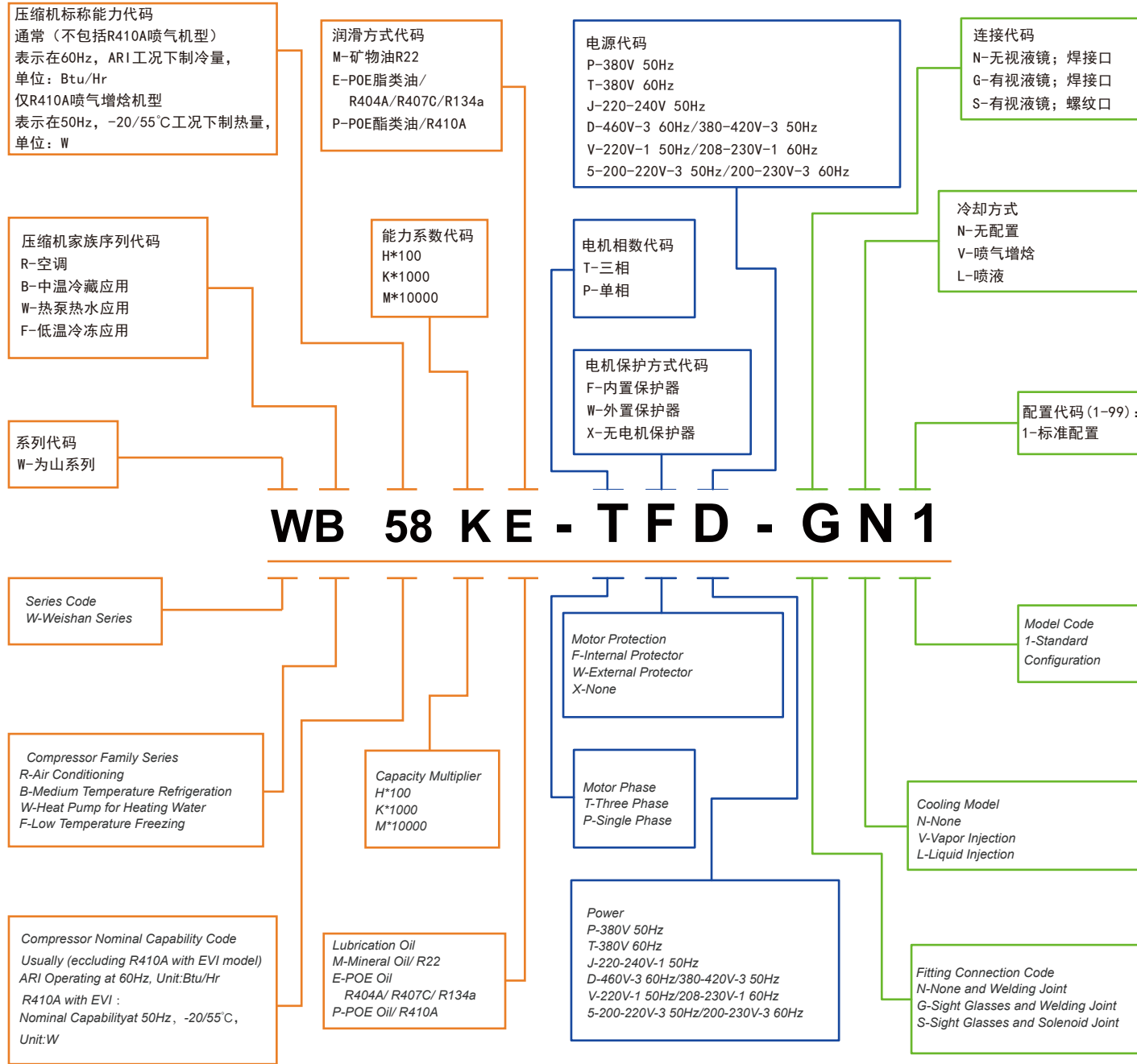

应用范围 Application Range

应用范围 APPLICATION RANGE

中温冷藏应用 WB Medium Temperature Refrigeration

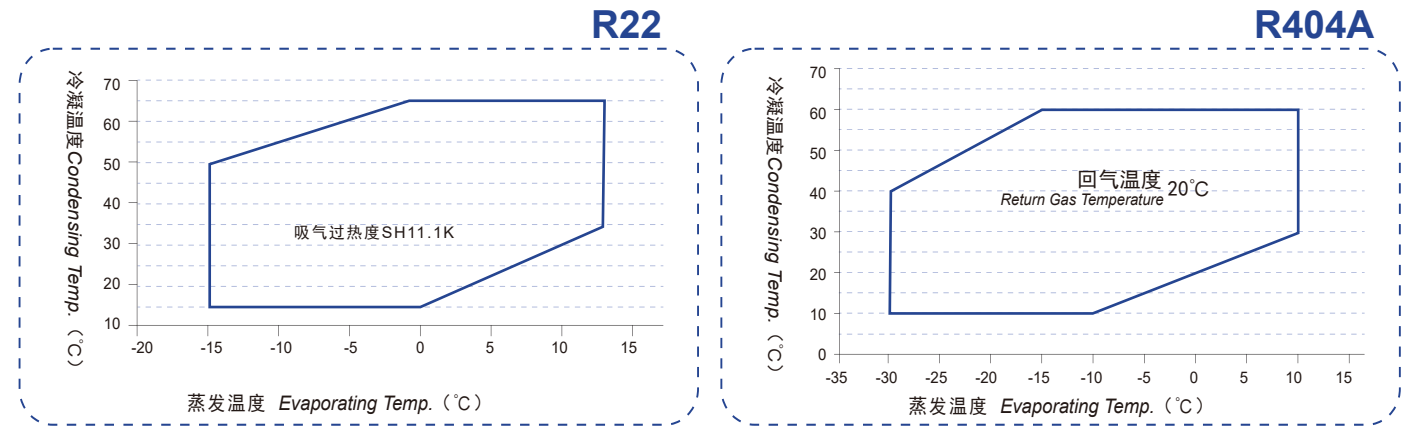

低温冷冻应用 WF Low Temperature Freezing

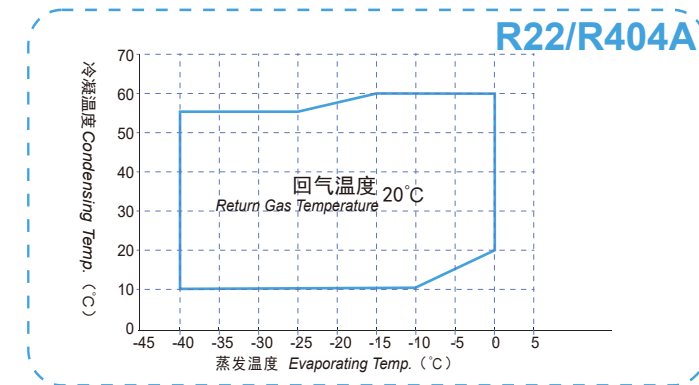

技术参数 Specifications

WB 中温冷藏应用 Medium Temperature Refrigeration

技术参数 SPECIFICATIONS

型号 Model	WB15KM-PFJ-GN1	WB22KM-PFJ-GN1	WB29KM-PFJ-GN1	WB15KM-TFD-GN1	WB22KM-TFD-GN1	WB29KM-TFD-GN1	WB40KM-TFD-GN1	WB45KM-TFD-GN1	WB48KM-TFD-GN1	
电制 Motor Power	220-240V/1~/50Hz			380-420V/3~/50Hz or 460V/3~/60Hz						
名义功率 Nominal Power(HP)	2	3	4	2	3	4	5	6	7	
排量 Displacement(CC/Rev)	37.2	50.6	63.9	37.2	50.6	63.9	84.5	98.9	108	
制冷剂 Refrigerant	R22									
名义制冷量 Nominal Capacity(W)	3639	4950	6251	3639	4950	6251	8650	10250	11850	
名义输入功率 Nominal Input Power(W)	1770	2338	2953	1719	2270	2867	3760	4430	5060	
名义工况能效比 COP(W/W)	2.06	2.12	2.12	2.12	2.18	2.18	2.32	2.31	2.34	
名义工况电流 Nominal Operating Current(A)	8	11	14	3.6	4.8	6.1	7.7	8.6	10.4	
堵转电流 LRA(A)	76	76	108	46	46	46	61	66	110	
最大运行电流 MOC(A)	14	18.5	23.3	5	6.6	8.3	11.4	13.6	15.3	
曲轴箱加热器功率 Crankcase Heater(W)	70									
接管内径尺寸 Fitting ID Size(mm)	排气管 Dis. Tube	12.94-13.10								
	吸气管 Suc. Tube	22.37-22.51								
外形尺寸 Dimension (mm)	长(L)*宽(W)*高(H)	244.4*230.5*403.4					233.6*230.5*442.7			
底脚安装尺寸(孔径) Mounting Dim.(Dia.)(mm)	190.5x190.5(9.0)									
润滑油类型 Lubrication Oil	3GS									
润滑油初次充注量 Lubrication Oil Initial Charge (L)	1.4					1.8				
润滑油重新充注量 Lubrication Oil Recharge (L)	1.2					1.6				
最大工作压力 Maximum Operating Pressures (MPa)	高压侧 High Pressure Side	3.0								
	低压侧 Low Pressure Side	2.0								
重量 Weight (kg)	30			28			36			

注: 蒸发温度-6.7°C, 冷凝温度48.9°C, 过热度11.1K, 无过冷度
Note: E.T. - 6.7 °C, C.T. 48.9 °C, S.H. 11.1K, No Subcooling

中温冷藏应用 WB Medium Temperature Refrigeration

技术参数 Specifications

技术参数 SPECIFICATIONS

型号 Model	WB58KM-TFD-GN1	WB76KM-TFD-GN1	WB89KM-TFD-GN1	WB110KM-TFD-GN1	WB150KM-TWD-GN1	WB190KM-TWD-GN1
电制 Motor Power	380-420V/3~/50Hz or 460V/3~/60Hz					
名义功率 Nominal Power(HP)	8	10	12	15	22	25
排量 Displacement(CC/Rev)	127	165.5	190.8	248.9	325	400
制冷剂 Refrigerant	R22					
名义制冷量 Nominal Capacity(W)	13260	18300	20060	25480	33270	40948
名义输入功率 Nominal Input Power(W)	5700	7750	8560	11220	14650	18031
名义工况能效比 COP(W/W)	2.33	2.36	2.36	2.27	2.27	2.27
名义工况电流 Nominal Operating Current(A)	11.3	13.5	14.8	19.2	27.1	32.2
堵转电流 LRA(A)	117	122	122	149	290	290
最大运行电流 MOC(A)	17.5	22.2	25.2	31.2	42.6	52.4
曲轴箱加热器功率 Crankcase Heater(W)	90					
接管内径尺寸 Fitting ID Size(mm)	排气管 Dis. Tube	22.37-22.51			28.81-28.95	
	吸气管 Suc. Tube	34.97-35.10				
外形尺寸 Dimension (mm)	长(L)*宽(W)*高(H)	281.4*273.7*523.7			337.34*333.77*649.7	
底脚安装尺寸(孔径) Mounting Dim.(Dia.)(mm)	190.5x190.5(8.5)					
润滑油类型 Lubrication Oil	3GS					
润滑油初次充注量 Lubrication Oil Initial Charge (L)	3.0	3.2	5.0			
润滑油重新充注量 Lubrication Oil Recharge (L)	2.8	3.0	4.8			
最大工作压力 Maximum Operating Pressures (MPa)	高压侧 High Pressure Side	3.0				
	低压侧 Low Pressure Side	2.0				
重量 Weight (kg)	66				92	

注: 蒸发温度-6.7°C, 冷凝温度48.9°C, 过热度11.1K, 无过冷度
Note: E.T. - 6.7 °C, C.T. 48.9 °C, S.H. 11.1K, No Subcooling

技术参数 Specifications

WB 中温冷藏应用 Medium Temperature Refrigeration

技术参数 SPECIFICATIONS

型号 Model	WB15KE-PFJ-GN1	WB22KE-PFJ-GN1	WB29KE-PFJ-GN1	WB15KE-TFD-GN1	WB22KE-TFD-GN1	WB29KE-TFD-GN1	WB40KE-TFD-GN1	WB45KE-TFD-GN1	WB48KE-TFD-GN1	
电制 Motor Power	220-240V/1~/50Hz			380-420V/3~/50Hz or 460V/3~/60Hz						
名义功率 Nominal Power(HP)	2	3	4	2	3	4	5	6	7	
排量 Displacement(CC/Rev)	37.2	50.6	63.9	37.2	50.6	63.9	84.5	98.9	108	
制冷剂 Refrigerant	R404A									
名义制冷量 Nominal Capacity(W)	3566	4850	6125	3566	4850	6125	8560	10150	11330	
名义输入功率 Nominal Input Power(W)	2098	2771	3499	2037	2690	3397	4260	5050	5510	
名义工况能效比 COP(W/W)	1.7	1.75	1.75	1.75	1.8	1.8	2.03	2.02	2.05	
名义工况电流 Nominal Operating Current(A)	10	13	17	3.9	5.2	6.6	8.1	9.5	11.3	
堵转电流 LRA(A)	76	76	108	46	46	46	61	66	110	
最大运行电流 MOC(A)	14.3	19.1	24.1	5.1	6.8	8.6	12.1	14.4	16.5	
曲轴箱加热器功率 Crankcase Heater(W)	70									
接管内径尺寸 Fitting ID Size(mm)	排气管 Dis. Tube	12.94-13.10								
	吸气管 Suc. Tube	22.37-22.51								
外形尺寸 Dimension (mm)	长(L)*宽(W)*高(H)	244.4*230.5*403.4					233.6*230.5*442.7			
底脚安装尺寸(孔径) Mounting Dim.(Dia.)(mm)	190.5x190.5(9.0)									
润滑油类型 Lubrication Oil	POE									
润滑油初次充注量 Lubrication Oil Initial Charge (L)	1.4					1.8				
润滑油重新充注量 Lubrication Oil Recharge (L)	1.2					1.6				
最大工作压力 Maximum Operating Pressures (MPa)	高压侧 High Pressure Side	3.2								
	低压侧 Low Pressure Side	2.0								
重量 Weight (kg)	30			28			36			

注: 蒸发温度-6.7°C, 冷凝温度48.9°C, 过热度11.1K, 无过冷度
Note: E.T. - 6.7°C, C.T. 48.9°C, S.H. 11.1K, No Subcooling

中温冷藏应用 WB Medium Temperature Refrigeration

技术参数 Specifications

技术参数 SPECIFICATIONS

型号 Model	WB58KE-TFD-GN1	WB76KE-TFD-GN1	WB89KE-TFD-GN1	WB110KE-TFD-GN1	WB150KE-TWD-GN1	WB190KE-TWD-GN1
电制 Motor Power	380-420V/3~/50Hz or 460V/3~/60Hz					
名义功率 Nominal Power(HP)	8	10	12	15	22	25
排量 Displacement(CC/Rev)	127	165.5	190.8	248.9	325	400
制冷剂 Refrigerant	R404A					
名义制冷量 Nominal Capacity(W)	12900	17860	19540	25210	32917	40514
名义输入功率 Nominal Input Power(W)	6450	8930	9670	12860	16792	20667
名义工况能效比 COP(W/W)	2.01	2.01	2.03	1.96	1.96	1.96
名义工况电流 Nominal Operating Current(A)	12.2	15.6	16.4	21.6	30	36.9
堵转电流 LRA(A)	117	122	122	149	290	290
最大运行电流 MOC(A)	18.5	23.7	26.6	32.9	44.7	55
曲轴箱加热器功率 Crankcase Heater(W)	90					
接管内径尺寸 Fitting ID Size(mm)	排气管 Dis. Tube	22.37-22.51			28.81-28.95	
	吸气管 Suc. Tube	34.97-35.10				
外形尺寸 Dimension (mm)	长(L)*宽(W)*高(H)	281.4*273.7*523.7			337.34*333.77*649.7	
底脚安装尺寸(孔径) Mounting Dim.(Dia.)(mm)	190.5x190.5(8.5)					
润滑油类型 Lubrication Oil	POE					
润滑油初次充注量 Lubrication Oil Initial Charge (L)	3.0	3.2	5.0			
润滑油重新充注量 Lubrication Oil Recharge (L)	2.8	3.0	4.8			
最大工作压力 Maximum Operating Pressures (MPa)	高压侧 High Pressure Side	3.2				
	低压侧 Low Pressure Side	2.0				
重量 Weight (kg)	66			92		

注: 蒸发温度-6.7°C, 冷凝温度48.9°C, 过热度11.1K, 无过冷度
Note: E.T. - 6.7°C, C.T. 48.9°C, S.H. 11.1K, No Subcooling

技术参数 Specifications

WF 低温冷冻应用 Low Temperature Freezing

型号 Model	WF06KE-PFJ-GL1	WF09KE-PFJ-GL1	WF13KE-PFJ-GL1	WF06KE-TFD-GL1	WF09KE-TFD-GL1	WF13KE-TFD-GL1	WF15KE-TFD-GL1
电制 Motor Power	220-240V/1~/50Hz			380-420V/3~/50Hz or 460V/3~/60Hz			
名义功率 Nominal Power(HP)	2	3	4	2	3	4	5
排量 Displacement(CC/Rev)	37.2	50.6	63.9	37.2	50.6	63.9	84.5
制冷剂 Refrigerant	R22						
名义制冷量 Nominal Capacity(W)	1559	2120	2677	1559	2120	2677	3550
名义输入功率 Nominal Input Power(W)	1451	1916	2420	1408	1860	2349	2750
名义工况能效比 COP(W/W)	1.07	1.11	1.11	1.11	1.14	1.14	1.29
名义工况电流 Nominal Operating Current(A)	7	9	11	3.3	4.4	5.6	6.4
堵转电流 LRA(A)	76	76	108	45	45	45	60
最大运行电流 MOC(A)	12.1	16	20.2	4.3	5.7	7.2	9.7
曲轴箱加热器功率 Crankcase Heater(W)	70	70	70	70	70	70	70
接管内径尺寸 Fitting ID Size(mm)	排气管 Dis. Tube	12.94-13.10					
	吸气管 Suc. Tube	22.37-22.51					
外形尺寸 Dimension (mm)	长(L)*宽(W)*高(H)	244.4*230.5*443					233.6*230.5*480
底脚安装尺寸(孔径) Mounting Dim.(Dia.)(mm)		190.5x190.5(9.0)					
润滑油类型 Lubrication Oil	POE						
润滑油初次充注量 Lubrication Oil Initial Charge (L)	1.4					1.8	
润滑油重新充注量 Lubrication Oil Recharge (L)	1.2					1.6	
最大工作压力 Maximum Operating Pressures (MPa)	高压侧 High Pressure Side	3.2					
	低压侧 Low Pressure Side	2.0					
重量 Weight (kg)	30			28			36

注: 蒸发温度-31.7℃, 冷凝温度40.6℃, 吸气温度20℃, 无过冷度
Note: E.T. - 31.7 °C, C.T. 40.6 °C, R.G. 20°C, No Subcooling

低温冷冻应用 WF Low Temperature Freezing

技术参数 Specifications

型号 Model	WF18KE-TFD-GL1	WF25KE-TFD-GL1	WF28KE-TFD-GL1	WF34KE-TFD-GL1	WF38KE-TFD-GL1	WF49KE-TFD-GL1	WF60KE-TWD-GL1	WF75KE-TWD-GL1
电制 Motor Power	380-420V/3~/50Hz or 460V/3~/60Hz							
名义功率 Nominal Power(HP)	6	7	8	10	12	15	22	25
排量 Displacement(CC/Rev)	98.9	108	127	165.5	190.8	248.9	325	400
制冷剂 Refrigerant	R22							
名义制冷量 Nominal Capacity(W)	4120	4490	5300	6900	7960	10350	13514	16633
名义输入功率 Nominal Input Power(W)	3170	3470	4100	5400	6120	8000	10446	12857
名义工况能效比 COP(W/W)	1.3	1.29	1.29	1.28	1.3	1.29	1.29	1.29
名义工况电流 Nominal Operating Current(A)	6.6	7.8	9.1	10.3	11.2	15.4	20.1	24.7
堵转电流 LRA(A)	60	88	116	116	129	152	290	290
最大运行电流 MOC(A)	11.6	14.2	17	21.5	23.3	32	41.8	51.4
曲轴箱加热器功率 Crankcase Heater(W)	70	70	90	90	90	90	90	90
接管内径尺寸 Fitting ID Size(mm)	排气管 Dis. Tube	12.94-13.10		22.37-22.51			28.81-28.95	
	吸气管 Suc. Tube	22.37-22.51		34.97-35.10				
外形尺寸 Dimension (mm)	长(L)*宽(W)*高(H)	233.6*230.5*480		281.4*273.7*563			337.34*333.77*649.7	
底脚安装尺寸(孔径) Mounting Dim.(Dia.)(mm)		190.5x190.5(9.0)		190.5x190.5(8.5)				
润滑油类型 Lubrication Oil	POE							
润滑油初次充注量 Lubrication Oil Initial Charge (L)	1.8		3.0		3.2		5.0	
润滑油重新充注量 Lubrication Oil Recharge (L)	1.6		2.8		3.0		4.8	
最大工作压力 Maximum Operating Pressures (MPa)	高压侧 High Pressure Side	3.2						
	低压侧 Low Pressure Side	2.0						
重量 Weight (kg)	36			66			92	

注: 蒸发温度-31.7℃, 冷凝温度40.6℃, 吸气温度20℃, 无过冷度
Note: E.T. - 31.7 °C, C.T. 40.6 °C, R.G. 20°C, No Subcooling

技术参数 Specifications

WF 低温冷冻应用 Low Temperature Freezing

型号 Model	WF06KE-PFJ-GL1	WF09KE-PFJ-GL1	WF13KE-PFJ-GL1	WF06KE-TFD-GL1	WF09KE-TFD-GL1	WF13KE-TFD-GL1	WF15KE-TFD-GL1
电制 Motor Power	220-240V/1~/50Hz			380-420V/3~/50Hz or 460V/3~/60Hz			
名义功率 Nominal Power(HP)	2	3	4	2	3	4	5
排量 Displacement(CC/Rev)	37.2	50.6	63.9	37.2	50.6	63.9	84.5
制冷剂 Refrigerant	R404A						
名义制冷量 Nominal Capacity(W)	1662	2260	2854	1662	2260	2854	3780
名义输入功率 Nominal Input Power(W)	1544	2039	2575	1499	1980	2500	2930
名义工况能效比 COP(W/W)	1.08	1.11	1.11	1.11	1.14	1.14	1.29
名义工况电流 Nominal Operating Current(A)	7	10	12	3.5	4.6	5.8	6.7
堵转电流 LRA(A)	76	76	108	45	45	45	60
最大运行电流 MOC(A)	12.3	16.3	20.5	4.4	5.8	7.3	10.4
曲轴箱加热器功率 Crankcase Heater(W)	70	70	70	70	70	70	70
接管内径尺寸 Fitting ID Size(mm)	排气管 Dis. Tube	12.94-13.10					
	吸气管 Suc. Tube	22.37-22.51					
外形尺寸 Dimension (mm)	长(L)*宽(W)*高(H)			244.4*230.5*443			233.6*230.5*480
底脚安装尺寸(孔径) Mounting Dim.(Dia.)(mm)	190.5x190.5(9.0)						
润滑油类型 Lubrication Oil	POE						
润滑油初次充注量 Lubrication Oil Initial Charge (L)	1.4			1.8			
润滑油重新充注量 Lubrication Oil Recharge (L)	1.2			1.6			
最大工作压力 Maximum Operating Pressures (MPa)	高压侧 High Pressure Side	3.2					
	低压侧 Low Pressure Side	2.0					
重量 Weight (kg)	30			28			36

注: 蒸发温度-31.7℃, 冷凝温度40.6℃, 吸气温度20℃, 无过冷度
Note: E.T. - 31.7 °C, C.T. 40.6 °C, R.G. 20°C, No Subcooling

WF 低温冷冻应用 Low Temperature Freezing

技术参数 Specifications

型号 Model	WF18KE-TFD-GL1	WF25KE-TFD-GL1	WF28KE-TFD-GL1	WF34KE-TFD-GL1	WF38KE-TFD-GL1	WF49KE-TFD-GL1	WF60KE-TWD-GL1	WF75KE-TWD-GL1
电制 Motor Power	380-420V/3~/50Hz or 460V/3~/60Hz							
名义功率 Nominal Power(HP)	6	7	8	10	12	15	22	25
排量 Displacement(CC/Rev)	98.9	108	127	165.5	190.8	248.9	325	400
制冷剂 Refrigerant	R404A							
名义制冷量 Nominal Capacity(W)	4400	4800	5690	7540	8740	11390	14872	18305
名义输入功率 Nominal Input Power(W)	3380	3690	4340	5800	6670	8700	11360	13982
名义工况能效比 COP(W/W)	1.3	1.3	1.31	1.3	1.31	1.31	1.31	1.31
名义工况电流 Nominal Operating Current(A)	7.1	8.4	9.8	11.1	12.6	16.6	21.7	26.7
堵转电流 LRA(A)	60	88	116	116	129	152	290	290
最大运行电流 MOC(A)	12.2	14.9	17.9	22.6	25.8	33.6	43.9	54.0
曲轴箱加热器功率 Crankcase Heater(W)	70	70	90	90	90	90	90	90
接管内径尺寸 Fitting ID Size(mm)	排气管 Dis. Tube	12.94-13.10		22.37-22.51			28.81-28.95	
	吸气管 Suc. Tube	22.37-22.51		34.97-35.10				
外形尺寸 Dimension (mm)	长(L)*宽(W)*高(H)		233.6*230.5*480		281.4*273.7*563		337.34*333.77*649.7	
底脚安装尺寸(孔径) Mounting Dim.(Dia.)(mm)	190.5x190.5(9.0)		190.5x190.5(8.5)					
润滑油类型 Lubrication Oil	POE							
润滑油初次充注量 Lubrication Oil Initial Charge (L)	1.8		3.0		3.2		5.0	
润滑油重新充注量 Lubrication Oil Recharge (L)	1.6		2.8		3.0		4.8	
最大工作压力 Maximum Operating Pressures (MPa)	高压侧 High Pressure Side	3.2						
	低压侧 Low Pressure Side	2.0						
重量 Weight (kg)	36		66			92		

注: 蒸发温度-31.7℃, 冷凝温度40.6℃, 吸气温度20℃, 无过冷度
Note: E.T. - 31.7 °C, C.T. 40.6 °C, R.G. 20°C, No Subcooling

制冷量-R22

Cooling Capacity - R22

WB 中温冷藏应用

Medium Temperature Refrigeration

制冷量 COOLING CAPACITY

型号 Model	项目 Item (W)	Tc\Te	-15°C	-10°C	-5°C	0°C	5°C	10°C
WB15KM-PFJ-GN1	Q	65°C				3991	4772	5713
	P					2618	2666	2693
	Q	60°C			3593	4314	5167	6180
	P				2310	2362	2404	2428
	Q	55°C		3168	3851	4637	5555	6633
	P		2041	2085	2130	2168	2189	
	Q	50°C	2704	3371	4112	4957	5933	7068
	P		1823	1845	1881	1921	1956	1977
	Q	45°C	2861	3580	4373	5269	6295	7481
	P		1654	1667	1697	1733	1767	1788
	Q	40°C	3027	3791	4629	5569	6640	7869
	P		1499	1505	1531	1565	1598	1622
	Q	35°C	3199	4001	4877	5854	6961	8227
	P		1358	1359	1381	1414	1449	1475
	Q	30°C	3373	4206	5112	6119	7257	8552
	P		1229	1225	1245	1279	1316	1348
	Q	25°C	3544	4401	5331	6361	7522	
	P		1109	1103	1123	1158	1200	
Q	20°C	3710	4583	5529	6576			
P		998	991	1012	1051			
Q	15°C	3865	4749	5704	6760			
P		894	887	910	954			
WB22KM-PFJ-GN1	Q	65°C				5429	6491	7771
	P					3457	3521	3556
	Q	60°C			4887	5868	7028	8406
	P				3050	3119	3175	3206
	Q	55°C		4309	5238	6308	7556	9022
	P		2696	2753	2813	2864	2891	
	Q	50°C	3677	4585	5594	6743	8070	9614
	P		2408	2437	2484	2537	2584	2611
	Q	45°C	3891	4869	5948	7167	8563	10176
	P		2184	2201	2241	2289	2334	2361
	Q	40°C	4118	5157	6296	7575	9031	10703
	P		1980	1988	2021	2066	2111	2141
	Q	35°C	4352	5442	6633	7962	9469	11191
	P		1793	1794	1823	1867	1913	1949
	Q	30°C	4588	5721	6953	8323	9870	11632
	P		1622	1618	1645	1689	1739	1780
	Q	25°C	4821	5986	7251	8653	10231	
	P		1465	1457	1483	1530	1585	
Q	20°C	5046	6234	7521	8945			
P		1319	1309	1336	1387			
Q	15°C	5257	6459	7759	9196			
P		1181	1172	1202	1259			

注: 1. 测试条件: 过热度11.1K, 过冷度0°C
2. Q--制冷量 (W) P--功率 (W)

Note: 1. Test conditions: Superheat 11.1K, subcooling 0°C
2. Q--Capacity(W) P--Power(W)

中温冷藏应用

Medium Temperature Refrigeration

WB

制冷量-R22

Cooling Capacity - R22

制冷量 COOLING CAPACITY

型号 Model	项目 Item (W)	Tc\Te	-15°C	-10°C	-5°C	0°C	5°C	10°C
WB29KM-PFJ-GN1	Q	65°C				6855	8197	9814
	P					4366	4446	4491
	Q	60°C			6172	7411	8876	10616
	P				3852	3939	4010	4048
	Q	55°C		5442	6615	7966	9542	11394
	P		3404	3477	3553	3616	3651	
	Q	50°C	4644	5790	7064	8515	10191	12141
	P		3041	3077	3137	3204	3263	3297
	Q	45°C	4914	6149	7512	9050	10814	12851
	P		2758	2780	2830	2891	2947	2982
	Q	40°C	5200	6512	7951	9566	11405	13517
	P		2500	2511	2552	2610	2666	2704
	Q	35°C	5495	6873	8377	10055	11958	14132
	P		2265	2266	2302	2358	2416	2461
	Q	30°C	5794	7224	8781	10511	12465	14690
	P		2049	2043	2077	2133	2196	2248
	Q	25°C	6088	7560	9157	10927	12920	
	P		1850	1840	1873	1932	2001	
Q	20°C	6372	7873	9498	11297			
P		1665	1653	1687	1752			
Q	15°C	6639	8157	9798	11613			
P		1492	1480	1518	1590			
WB15KM-TFD-GN1	Q	65°C				3991	4772	5713
	P					2542	2589	2614
	Q	60°C			3593	4314	5167	6180
	P				2242	2293	2334	2357
	Q	55°C		3168	3851	4637	5555	6633
	P		1982	1982	2024	2068	2105	2126
	Q	50°C	2704	3371	4112	4957	5933	7068
	P		1770	1791	1826	1865	1900	1919
	Q	45°C	2861	3580	4373	5269	6295	7481
	P		1606	1618	1647	1683	1716	1736
	Q	40°C	3027	3791	4629	5569	6640	7869
	P		1455	1462	1486	1519	1552	1574
	Q	35°C	3199	4001	4877	5854	6961	8227
	P		1318	1319	1340	1373	1406	1433
	Q	30°C	3373	4206	5112	6119	7257	8552
	P		1193	1190	1209	1242	1278	1309
	Q	25°C	3544	4401	5331	6361	7522	
	P		1077	1071	1090	1125	1165	
Q	20°C	3710	4583	5529	6576			
P		969	962	982	1020			
Q	15°C	3865	4749	5704	6760			
P		868	861	884	926			

注: 1. 测试条件: 过热度11.1K, 过冷度0°C
2. Q--制冷量 (W) P--功率 (W)

Note: 1. Test conditions: Superheat 11.1K, subcooling 0°C
2. Q--Capacity(W) P--Power(W)

制冷量-R22

Cooling Capacity - R22

WB 中温冷藏应用

Medium Temperature Refrigeration

制冷量 COOLING CAPACITY

型号 Model	项目 Item (W)	Tc\Te	-15°C	-10°C	-5°C	0°C	5°C	10°C
WB22KM-TFD-GN1	Q	65°C				5429	6491	7771
	P					3356	3418	3453
	Q	60°C			4887	5868	7028	8406
	P				2961	3028	3083	3112
	Q	55°C		4309	5238	6308	7556	9022
	P			2617	2673	2731	2780	2807
	Q	50°C	3677	4585	5594	6743	8070	9614
	P		2338	2366	2412	2463	2508	2535
	Q	45°C	3891	4869	5948	7167	8563	10176
	P		2120	2137	2175	2222	2266	2293
	Q	40°C	4118	5157	6296	7575	9031	10703
	P		1922	1930	1962	2006	2049	2079
	Q	35°C	4352	5442	6633	7962	9469	11191
	P		1741	1742	1770	1813	1857	1892
	Q	30°C	4588	5721	6953	8323	9870	11632
	P		1575	1571	1597	1640	1688	1729
	Q	25°C	4821	5986	7251	8653	10231	
	P		1422	1415	1440	1485	1539	
Q	20°C	5046	6234	7521	8945			
P		1280	1271	1297	1347			
Q	15°C	5257	6459	7759	9196			
P		1147	1138	1167	1223			
WB29KM-TFD-GN1	Q	65°C				6855	8197	9814
	P					4239	4317	4360
	Q	60°C			6172	7411	8876	10616
	P				3740	3824	3893	3931
	Q	55°C		5442	6615	7966	9542	11394
	P			3305	3375	3449	3511	3545
	Q	50°C	4644	5790	7064	8515	10191	12141
	P		2952	2987	3045	3111	3168	3201
	Q	45°C	4914	6149	7512	9050	10814	12851
	P		2678	2699	2747	2806	2861	2895
	Q	40°C	5200	6512	7951	9566	11405	13517
	P		2427	2437	2478	2534	2588	2626
	Q	35°C	5495	6873	8377	10055	11958	14132
	P		2199	2200	2235	2289	2346	2389
	Q	30°C	5794	7224	8781	10511	12465	14690
	P		1989	1984	2016	2071	2132	2183
	Q	25°C	6088	7560	9157	10927	12920	
	P		1796	1786	1818	1876	1943	
Q	20°C	6372	7873	9498	11297			
P		1617	1605	1638	1701			
Q	15°C	6639	8157	9798	11613			
P		1448	1437	1474	1544			

注: 1. 测试条件: 过热度11.1K, 过冷度0°C
2. Q--制冷量 (W) P--功率 (W)

Note: 1. Test conditions: Superheat 11.1K, subcooling 0°C
2. Q--Capacity(W) P--Power(W)

中温冷藏应用

Medium Temperature Refrigeration

WB

制冷量-R22

Cooling Capacity - R22

制冷量 COOLING CAPACITY

型号 Model	项目 Item (W)	Tc\Te	-15°C	-10°C	-5°C	0°C	5°C	10°C
WB40KM-TFD-GN1	Q	65°C				9065	10839	12978
	P					5605	5709	5766
	Q	60°C			8162	9800	11737	14038
	P				4945	5057	5148	5198
	Q	55°C		7196	8748	10534	12619	15067
	P			4371	4463	4561	4643	4688
	Q	50°C	6141	7657	9341	11260	13476	16055
	P		3904	3950	4027	4114	4189	4233
	Q	45°C	6498	8131	9933	11968	14300	16993
	P		3541	3569	3633	3711	3783	3829
	Q	40°C	6876	8612	10515	12650	15082	17874
	P		3210	3223	3277	3350	3422	3472
	Q	35°C	7267	9089	11077	13297	15812	18688
	P		2907	2909	2956	3027	3102	3159
	Q	30°C	7661	9553	11611	13900	16483	19426
	P		2630	2623	2666	2738	2819	2887
	Q	25°C	8051	9997	12109	14450	17085	
	P		2375	2362	2404	2480	2569	
Q	20°C	8427	10411	12560	14938			
P		2138	2122	2166	2249			
Q	15°C	8779	10786	12957	15356			
P		1915	1900	1949	2042			
WB45KM-TFD-GN1	Q	65°C				10610	12687	15189
	P					6560	6681	6748
	Q	60°C			9553	11470	13737	16430
	P				5788	5919	6025	6083
	Q	55°C		8423	10239	12329	14769	17634
	P			5115	5224	5338	5434	5487
	Q	50°C	7188	8962	10933	13179	15773	18791
	P		4570	4624	4713	4815	4903	4954
	Q	45°C	7605	9517	11626	14008	16737	19889
	P		4144	4177	4252	4344	4428	4481
	Q	40°C	8048	10079	12307	14806	17652	20920
	P		3757	3773	3836	3921	4005	4064
	Q	35°C	8505	10637	12965	15563	18507	21872
	P		3403	3405	3460	3543	3630	3698
	Q	30°C	8967	11181	13590	16269	19292	22736
	P		3079	3071	3121	3205	3299	3379
	Q	25°C	9423	11701	14172	16912	19997	
	P		2780	2765	2814	2903	3007	
Q	20°C	9863	12185	14701	17484			
P		2502	2484	2536	2633			
Q	15°C	10275	12625	15165	17973			
P		2241	2224	2281	2390			

注: 1. 测试条件: 过热度11.1K, 过冷度0°C
2. Q--制冷量 (W) P--功率 (W)

Note: 1. Test conditions: Superheat 11.1K, subcooling 0°C
2. Q--Capacity(W) P--Power(W)

制冷量-R22

Cooling Capacity - R22

WB 中温冷藏应用

Medium Temperature Refrigeration

制冷量 COOLING CAPACITY

型号 Model	项目 Item (W)	Tc\Te	-15°C	-10°C	-5°C	0°C	5°C	10°C
WB48KM-TFD-GN1	Q	65°C				11587	13854	16587
	P					7164	7296	7369
	Q	60°C			10432	12525	15001	17942
	P				6321	6463	6580	6643
	Q	55°C		9198	11181	13464	16128	19257
	P			5586	5705	5829	5934	5992
	Q	50°C	7849	9786	11939	14391	17224	20520
	P		4990	5049	5147	5258	5354	5410
	Q	45°C	8305	10393	12696	15296	18277	21719
	P		4525	4562	4643	4743	4836	4893
	Q	40°C	8788	11007	13439	16168	19276	22845
	P		4102	4120	4188	4282	4374	4437
	Q	35°C	9288	11616	14158	16995	20210	23885
	P		3716	3718	3778	3869	3964	4038
	Q	30°C	9792	12210	14840	17765	21067	24828
	P		3362	3353	3408	3500	3603	3690
	Q	25°C	10290	12777	15476	18469	21837	
	P		3036	3019	3073	3170	3284	
Q	20°C	10770	13306	16053	19093			
P		2732	2713	2769	2875			
Q	15°C	11221	13786	16561	19627			
P		2448	2428	2491	2610			
WB58KM-TFD-GN1	Q	65°C				13625	16291	19505
	P					8424	8580	8666
	Q	60°C			12267	14728	17640	21099
	P				7432	7601	7737	7812
	Q	55°C		10816	13148	15832	18965	22644
	P			6569	6708	6855	6978	7046
	Q	50°C	9230	11508	14040	16923	20254	24129
	P		5868	5937	6053	6183	6296	6362
	Q	45°C	9766	12221	14929	17988	21492	25540
	P		5322	5364	5460	5578	5686	5754
	Q	40°C	10335	12943	15803	19013	22667	26864
	P		4824	4844	4925	5035	5143	5218
	Q	35°C	10922	13660	16648	19985	23765	28087
	P		4370	4372	4443	4550	4662	4748
	Q	30°C	11515	14358	17451	20891	24774	29196
	P		3954	3943	4007	4116	4236	4339
	Q	25°C	12100	15025	18199	21718	25678	
	P		3570	3550	3614	3728	3862	
Q	20°C	12665	15647	18878	22452			
P		3213	3190	3256	3381			
Q	15°C	13195	16212	19474	23080			
P		2878	2855	2929	3069			

注: 1. 测试条件: 过热度11.1K, 过冷度0°C
2. Q--制冷量 (W) P--功率 (W)

Note: 1. Test conditions: Superheat 11.1K, subcooling 0°C
2. Q--Capacity(W) P--Power(W)

中温冷藏应用

Medium Temperature Refrigeration

WB

制冷量-R22

Cooling Capacity - R22

制冷量 COOLING CAPACITY

型号 Model	项目 Item (W)	Tc\Te	-15°C	-10°C	-5°C	0°C	5°C	10°C
WB76KM-TFD-GN1	Q	65°C				17755	21230	25418
	P					10978	11181	11293
	Q	60°C			15986	19193	22988	27495
	P				9686	9905	10083	10180
	Q	55°C		14095	17134	20632	24715	29509
	P			8560	8742	8933	9093	9182
	Q	50°C	12028	14996	18296	22053	26394	31444
	P		7647	7737	7887	8057	8205	8290
	Q	45°C	12727	15926	19455	23440	28008	33283
	P		6935	6990	7115	7269	7410	7499
	Q	40°C	13468	16867	20594	24776	29539	35008
	P		6287	6313	6418	6562	6703	6800
	Q	35°C	14233	17801	21695	26043	30970	36601
	P		5695	5698	5790	5929	6075	6187
	Q	30°C	15006	18711	22742	27224	32284	38047
	P		5152	5138	5222	5363	5521	5654
	Q	25°C	15768	19580	23716	28301	33463	
	P		4652	4627	4709	4858	5032	
Q	20°C	16504	20391	24600	29258			
P		4187	4157	4243	4405			
Q	15°C	17195	21126	25378	30077			
P		3751	3721	3817	3999			
WB89KM-TFD-GN1	Q	65°C				20470	24475	29304
	P					12657	12890	13019
	Q	60°C			18429	22127	26502	31698
	P				11166	11419	11624	11736
	Q	55°C		16249	19753	23786	28493	34020
	P			9869	10078	10299	10483	10585
	Q	50°C	13867	17289	21093	25424	30429	36251
	P		8816	8920	9093	9289	9459	9557
	Q	45°C	14672	18361	22429	27024	32289	38371
	P		7995	8059	8203	8380	8543	8645
	Q	40°C	15526	19445	23742	28564	34054	40359
	P		7248	7278	7400	7565	7727	7840
	Q	35°C	16409	20522	25012	30024	35704	42197
	P		6565	6569	6675	6835	7004	7133
	Q	30°C	17300	21571	26218	31386	37219	43863
	P		5940	5924	6021	6183	6365	6518
	Q	25°C	18179	22573	27341	32628	38578	
	P		5363	5334	5429	5600	5802	
Q	20°C	19027	23508	28361	33731			
P		4827	4792	4892	5079			
Q	15°C	19824	24356	29257	34674			
P		4324	4290	4401	4610			

注: 1. 测试条件: 过热度11.1K, 过冷度0°C
2. Q--制冷量 (W) P--功率 (W)

Note: 1. Test conditions: Superheat 11.1K, subcooling 0°C
2. Q--Capacity(W) P--Power(W)

制冷量-R22

Cooling Capacity - R22

WB 中温冷藏应用

Medium Temperature Refrigeration

制冷量 COOLING CAPACITY

型号 Model	项目 Item (W)	Tc\Te	-15°C	-10°C	-5°C	0°C	5°C	10°C
WB110KM-TFD-GN1	Q	65°C				26703	31928	38227
	P					16511	16815	16983
	Q	60°C			24041	28865	34572	41350
	P				14566	14896	15164	15310
	Q	55°C		21197	25768	31029	37169	44379
	P			12874	13147	13435	13676	13808
	Q	50°C	18089	22553	27516	33166	39695	47290
	P		11500	11636	11862	12117	12339	12468
	Q	45°C	19140	23952	29259	35253	42122	50055
	P		10430	10513	10701	10932	11144	11277
	Q	40°C	20254	25366	30972	37262	44424	52649
	P		9454	9494	9653	9868	10080	10227
	Q	35°C	21405	26771	32628	39167	46576	55046
	P		8564	8569	8707	8917	9136	9305
	Q	30°C	22567	28140	34202	40943	48552	57220
	P		7748	7728	7854	8066	8303	8503
	Q	25°C	23715	29447	35667	42563	50326	
	P		6996	6958	7082	7306	7568	
Q	20°C	24821	30666	36997	44002			
P		6297	6251	6381	6625			
Q	15°C	25860	31772	38167	45233			
P		5641	5596	5741	6014			
WB150KM-TWD-GN1	Q	65°C				34867	41690	49915
	P					21559	21956	22176
	Q	60°C			31392	37691	45142	53992
	P				19020	19450	19800	19991
	Q	55°C		27678	33646	40516	48534	57948
	P			16810	17167	17542	17857	18030
	Q	50°C	23620	29449	35929	43307	51831	61749
	P		15016	15194	15489	15822	16112	16280
	Q	45°C	24992	31275	38205	46031	55000	65359
	P		13618	13728	13973	14274	14551	14725
	Q	40°C	26447	33122	40442	48654	58007	68746
	P		12345	12397	12604	12886	13162	13354
	Q	35°C	27950	34956	42604	51142	60817	71876
	P		11183	11189	11369	11643	11930	12151
	Q	30°C	29467	36743	44659	53461	63397	74714
	P		10117	10090	10255	10532	10841	11103
	Q	25°C	30965	38450	46572	55577	65713	
	P		9135	9086	9247	9539	9882	
Q	20°C	32410	40043	48309	57455			
P		8223	8163	8332	8651			
Q	15°C	33767	41486	49836	59063			
P		7366	7307	7496	7853			

注: 1. 测试条件: 过热度11.1K, 过冷度0°C
2. Q--制冷量 (W) P--功率 (W)

Note: 1. Test conditions: Superheat 11.1K, subcooling 0°C
2. Q--Capacity(W) P--Power(W)

中温冷藏应用

Medium Temperature Refrigeration

WB

制冷量-R22

Cooling Capacity - R22

制冷量 COOLING CAPACITY

型号 Model	项目 Item (W)	Tc\Te	-15°C	-10°C	-5°C	0°C	5°C	10°C
WB190KM-TWD-GN1	Q	65°C				42913	51311	61434
	P					26534	27023	27293
	Q	60°C			38636	46389	55559	66452
	P				23409	23939	24370	24604
	Q	55°C		34066	41411	49865	59734	71321
	P			20690	21129	21591	21978	22191
	Q	50°C	29071	36245	44220	53301	63792	75998
	P		18481	18700	19063	19473	19830	20036
	Q	45°C	30760	38492	47022	56654	67692	80442
	P		16761	16895	17197	17568	17909	18123
	Q	40°C	32550	40765	49774	59882	71393	84611
	P		15194	15258	15513	15859	16199	16435
	Q	35°C	34400	43023	52436	62944	74852	88463
	P		13763	13772	13993	14330	14683	14955
	Q	30°C	36267	45223	54965	65798	78027	91956
	P		12452	12419	12622	12963	13343	13665
	Q	25°C	38111	47324	57319	68402	80877	
	P		11243	11183	11381	11741	12163	
Q	20°C	39889	49283	59457	70714			
P		10120	10046	10255	10647			
Q	15°C	41559	51060	61336	72693			
P		9065	8993	9226	9665			

注: 1. 测试条件: 过热度11.1K, 过冷度0°C
2. Q--制冷量 (W) P--功率 (W)

Note: 1. Test conditions: Superheat 11.1K, subcooling 0°C
2. Q--Capacity(W) P--Power(W)

制冷量-R404A

Cooling Capacity - R404A

WB 中温冷藏应用 Medium Temperature Refrigeration

制冷量 COOLING CAPACITY

型号 Model	项目 Item (W)	Tc\Te	-30°C	-25°C	-20°C	-15°C	-10°C	-5°C	0°C	5°C	10°C
WB15KE-PFJ-GN1	Q	60°C				2148	2733	3354	4021	4750	5553
	P					2679	2724	2751	2762	2756	2734
	Q	55°C				2612	3225	3893	4628	5445	6356
	P					2421	2455	2475	2480	2472	2451
	Q	50°C			2398	2982	3628	4349	5159	6069	7095
	P				2140	2178	2204	2218	2219	2210	2191
	Q	45°C		2138	2672	3275	3961	4742	5631	6642	7787
	P			1884	1924	1953	1971	1980	1980	1972	1957
	Q	40°C	1881	2344	2882	3511	4241	5088	6063	7180	8452
	P		1657	1694	1723	1744	1757	1763	1758	1758	1749
	Q	35°C	2044	2497	3047	3706	4488	5406	6473	7702	9107
	P		1493	1519	1538	1552	1561	1566	1569	1568	1566
	Q	30°C	2167	2617	3183	3880	4719	5715	6880	8227	9770
	P		1342	1357	1369	1378	1385	1391	1397	1403	1410
	Q	25°C	2269	2721	3311	4050	4953	6033	7301	8773	
	P		1204	1211	1216	1223	1230	1238	1249	1263	
	Q	20°C	2367	2828	3447	4235	5208	6377	7756		
	P		1080	1079	1081	1086	1094	1107	1126		
	Q	15°C	2481	2956	3610	4454	5502	6767			
	P		970	964	964	969	981	999			
Q	10°C	2628	3124	3818	4724	5854					
P		874	865	864	872	888					
WB22KE-PFJ-GN1	Q	60°C				2921	3718	4562	5470	6461	7553
	P					3537	3597	3634	3647	3639	3611
	Q	55°C				3553	4387	5295	6296	7406	8645
	P					3197	3242	3268	3275	3264	3236
	Q	50°C			3262	4056	4935	5916	7017	8256	9650
	P				2826	2877	2911	2929	2931	2919	2894
	Q	45°C		2909	3635	4455	5387	6449	7659	9034	10592
	P			2488	2541	2579	2603	2615	2615	2605	2585
	Q	40°C	2559	3188	3921	4775	5769	6920	8247	9766	11496
	P		2188	2238	2275	2302	2328	2328	2322	2309	
	Q	35°C	2781	3397	4144	5041	6105	7353	8805	10477	12387
	P		1972	2005	2031	2049	2062	2069	2072	2071	2068
	Q	30°C	2948	3560	4330	5277	6419	7774	9358	11191	13289
	P		1772	1792	1808	1820	1829	1838	1845	1853	1862
	Q	25°C	3086	3701	4503	5509	6737	8206	9932	11933	
	P		1590	1599	1606	1615	1624	1635	1650	1668	
	Q	20°C	3220	3847	4688	5761	7084	8674	10550		
	P		1426	1425	1428	1434	1445	1462	1486		
	Q	15°C	3374	4021	4910	6058	7484	9205			
	P		1281	1273	1273	1279	1295	1320			
Q	10°C	3574	4249	5194	6426	7962					
P		1155	1143	1141	1151	1173					

注: 1. 测试条件: 吸气温度20°C, 过冷度0°C
2. Q--制冷量 (W) P--功率 (W)

Note: 1. Test conditions: R.G. 20°C, subcooling 0°C
2. Q--Capacity(W) P--Power(W)

中温冷藏应用 WB Medium Temperature Refrigeration

制冷量-R404A

Cooling Capacity - R404A

制冷量 COOLING CAPACITY

型号 Model	项目 Item (W)	Tc\Te	-30°C	-25°C	-20°C	-15°C	-10°C	-5°C	0°C	5°C	10°C
WB29KE-PFJ-GN1	Q	60°C				3689	4695	5760	6908	8160	9538
	P					4467	4543	4589	4606	4596	4560
	Q	55°C				4487	5540	6687	7950	9353	10918
	P					4037	4095	4127	4136	4122	4087
	Q	50°C			4119	5122	6232	7471	8861	10426	12187
	P				3568	3633	3676	3698	3701	3686	3655
	Q	45°C		3673	4590	5626	6804	8145	9672	11409	13376
	P			3142	3208	3256	3287	3302	3303	3289	3264
	Q	40°C	3232	4026	4951	6030	7285	8739	10414	12333	14518
	P		2763	2826	2873	2908	2929	2940	2940	2932	2916
	Q	35°C	3512	4290	5233	6366	7709	9286	11119	13230	15643
	P		2490	2532	2565	2588	2604	2612	2616	2615	2612
	Q	30°C	3723	4495	5468	6664	8106	9817	11818	14132	16782
	P		2238	2263	2283	2298	2310	2320	2330	2340	2352
	Q	25°C	3898	4674	5687	6957	8508	10362	12542	15070	
	P		2008	2019	2029	2039	2051	2065	2083	2107	
	Q	20°C	4067	4858	5920	7275	8946	10954	13323		
	P		1801	1800	1803	1811	1825	1847	1877		
	Q	15°C	4261	5078	6201	7651	9451	11624			
	P		1617	1608	1607	1616	1635	1667			
Q	10°C	4513	5366	6559	8114	10055					
P		1458	1443	1441	1454	1481					
WB15KE-TFD-GN1	Q	60°C				2148	2733	3354	4021	4750	5553
	P					2600	2645	2671	2681	2676	2654
	Q	55°C				2612	3225	3893	4628	5445	6356
	P					3197	3242	3268	3275	3264	3236
	Q	50°C			3262	4056	4935	5916	7017	8256	9650
	P				2826	2877	2911	2929	2931	2919	2894
	Q	45°C		2909	3635	4455	5387	6449	7659	9034	10592
	P			2488	2541	2579	2603	2615	2615	2605	2585
	Q	40°C	2559	3188	3921	4775	5769	6920	8247	9766	11496
	P		2188	2238	2275	2302	2328	2328	2322	2309	
	Q	35°C	2781	3397	4144	5041	6105	7353	8805	10477	12387
	P		1972	2005	2031	2049	2062	2069	2072	2071	2068
	Q	30°C	2948	3560	4330	5277	6419	7774	9358	11191	13289
	P		1772	1792	1808	1820	1829	1838	1845	1853	1862
	Q	25°C	3086	3701	4503	5509	6737	8206	9932	11933	
	P		1590	1599	1606	1615	1624	1635	1650	1668	
	Q	20°C	3220	3847	4688	5761	7084	8674	10550		
	P		1426	1425	1428	1434	1445	1462	1486		
	Q	15°C	3374	4021	4910	6058	7484	9205			
	P		1281	1273	1273	1279	1295	1320			
Q	10°C	3574	4249	5194	6426	7962					
P		1155	1143	1141	1151	1173					

注: 1. 测试条件: 吸气温度20°C, 过冷度0°C
2. Q--制冷量 (W) P--功率 (W)

Note: 1. Test conditions: R.G. 20°C, subcooling 0°C
2. Q--Capacity(W) P--Power(W)

制冷量-R404A

Cooling Capacity - R404A

WB 中温冷藏应用 Medium Temperature Refrigeration

制冷量 COOLING CAPACITY

型号 Model	项目 Item (W)	Tc\Te	-30°C	-25°C	-20°C	-15°C	-10°C	-5°C	0°C	5°C	10°C
WB22KE-TFD-GN1	Q	60°C				2921	3718	4562	5470	6461	7553
	P					3434	3492	3528	3541	3533	3506
	Q	55°C				3553	4387	5295	6296	7406	8645
	P					3103	3148	3173	3180	3169	3142
	Q	50°C			3262	4056	4935	5916	7017	8256	9650
	P				2743	2793	2826	2843	2846	2834	2810
	Q	45°C		2909	3635	4455	5387	6449	7659	9034	10592
	P			2416	2467	2503	2527	2539	2539	2529	2510
	Q	40°C	2559	3188	3921	4775	5769	6920	8247	9766	11496
	P		2124	2172	2209	2235	2252	2260	2261	2254	2242
	Q	35°C	2781	3397	4144	5041	6105	7353	8805	10477	12387
	P		1914	1947	1972	1990	2002	2008	2011	2011	2008
	Q	30°C	2948	3560	4330	5277	6419	7774	9358	11191	13289
	P		1721	1740	1755	1767	1776	1784	1791	1799	1808
	Q	25°C	3086	3701	4503	5509	6737	8206	9932	11933	
	P		1544	1552	1560	1568	1576	1588	1602	1620	
	Q	20°C	3220	3847	4688	5761	7084	8674	10550		
	P		1384	1384	1386	1392	1403	1420	1443		
Q	15°C	3374	4021	4910	6058	7484	9205				
P		1243	1236	1236	1242	1257	1281				
Q	10°C	3574	4249	5194	6426	7962					
P		1121	1110	1108	1118	1139					
WB29KE-TFD-GN1	Q	60°C				3689	4695	5760	6908	8160	9538
	P					4337	4410	4455	4472	4462	4427
	Q	55°C				4487	5540	6687	7950	9353	10918
	P					3919	3975	4007	4016	4002	3968
	Q	50°C			4119	5122	6232	7471	8861	10426	12187
	P				3464	3527	3569	3591	3594	3579	3548
	Q	45°C		3673	4590	5626	6804	8145	9672	11409	13376
	P			3050	3115	3161	3191	3206	3206	3194	3169
	Q	40°C	3232	4026	4951	6030	7285	8739	10414	12333	14518
	P		2682	2743	2790	2823	2844	2854	2847	2832	
	Q	35°C	3512	4290	5233	6366	7709	9286	11119	13230	15643
	P		2417	2459	2490	2513	2528	2536	2540	2539	2536
	Q	30°C	3723	4495	5468	6664	8106	9817	11818	14132	16782
	P		2173	2197	2216	2231	2243	2253	2262	2272	2284
	Q	25°C	3898	4674	5687	6957	8508	10362	12542	15070	
	P		1950	1960	1970	1980	1991	2005	2023	2046	
	Q	20°C	4067	4858	5920	7275	8946	10954	13323		
	P		1748	1748	1751	1758	1772	1793	1822		
Q	15°C	4261	5078	6201	7651	9451	11624				
P		1570	1561	1560	1569	1588	1618				
Q	10°C	4513	5366	6559	8114	10055					
P		1416	1401	1399	1411	1438					

注: 1. 测试条件: 吸气温度20°C, 过冷度0°C
2. Q--制冷量 (W) P--功率 (W)

Note: 1. Test conditions: R.G. 20°C, subcooling 0°C
2. Q--Capacity(W) P--Power(W)

中温冷藏应用 WB Medium Temperature Refrigeration

制冷量-R404A

Cooling Capacity - R404A

制冷量 COOLING CAPACITY

型号 Model	项目 Item (W)	Tc\Te	-30°C	-25°C	-20°C	-15°C	-10°C	-5°C	0°C	5°C	10°C
WB40KE-TFD-GN1	Q	60°C				4878	6209	7618	9135	10790	12613
	P					5735	5832	5891	5913	5901	5854
	Q	55°C				5933	7326	8842	10513	12369	14438
	P					5183	5257	5299	5310	5292	5247
	Q	50°C			5447	6773	8241	9879	11718	13787	16115
	P				4581	4664	4719	4748	4752	4733	4692
	Q	45°C		4857	6070	7440	8997	10770	12790	15086	17688
	P			4034	4119	4181	4220	4240	4240	4223	4191
	Q	40°C	4274	5324	6548	7974	9634	11557	13772	16309	19198
	P		3547	3628	3689	3733	3761	3774	3765	3744	
	Q	35°C	4644	5672	6921	8418	10195	12280	14704	17496	20685
	P		3197	3251	3293	3323	3343	3354	3359	3358	3354
	Q	30°C	4923	5944	7231	8813	10720	12981	15628	18688	22193
	P		2873	2906	2931	2950	2966	2979	2991	3004	3020
	Q	25°C	5154	6181	7520	9200	11251	13703	16585	19928	
	P		2578	2592	2605	2618	2633	2651	2675	2705	
	Q	20°C	5377	6424	7829	9621	11830	14486	17618		
	P		2312	2311	2315	2325	2343	2371	2410		
Q	15°C	5635	6716	8200	10117	12498	15371				
P		2076	2064	2063	2074	2099	2140				
Q	10°C	5968	7096	8674	10730	13296					
P		1872	1853	1850	1866	1902					
WB45KE-TFD-GN1	Q	60°C				5710	7267	8916	10692	12629	14763
	P					6712	6826	6895	6921	6906	6852
	Q	55°C				6945	8574	10349	12305	14476	16898
	P					6066	6153	6202	6215	6194	6141
	Q	50°C			6375	7928	9646	11563	13715	16136	18862
	P				5362	5459	5524	5557	5562	5539	5492
	Q	45°C		5685	7104	8708	10530	12606	14970	17657	20703
	P			4721	4821	4893	4939	4962	4963	4943	4905
	Q	40°C	5002	6231	7663	9333	11276	13526	16119	19088	22469
	P		4152	4246	4318	4369	4402	4418	4418	4406	4382
	Q	35°C	5435	6639	8100	9853	11932	14373	17209	20477	24211
	P		3741	3805	3854	3889	3912	3926	3931	3930	3925
	Q	30°C	5762	6957	8463	10315	12547	15194	18291	21873	25975
	P		3363	3401	3430	3453	3472	3487	3501	3516	3534
	Q	25°C	6032	7234	8801	10768	13168	16038	19412	23324	
	P		3017	3034	3048	3064	3081	3103	3131	3166	
	Q	20°C	6294	7519	9163	11260	13846	16954	20620		
	P		2706	2705	2710	2722	2743	2775	2821		
Q	15°C	6595	7860	9597	11841	14628	17991				
P		2430	2416	2415	2428	2457	2505				
Q	10°C	6986	8305	10152	12559	15562					
P		2191	2169	2166	2184	2226					

注: 1. 测试条件: 吸气温度20°C, 过冷度0°C
2. Q--制冷量 (W) P--功率 (W)

Note: 1. Test conditions: R.G. 20°C, subcooling 0°C
2. Q--Capacity(W) P--Power(W)

制冷量-R404A

Cooling Capacity - R404A

WB 中温冷藏应用 Medium Temperature Refrigeration

制冷量 COOLING CAPACITY

型号 Model	项目 Item (W)	Tc\Te	-30°C	-25°C	-20°C	-15°C	-10°C	-5°C	0°C	5°C	10°C
WB48KE-TFD-GN1	Q	60°C				6235	7935	9736	11675	13791	16121
	P					7330	7454	7530	7558	7542	7482
	Q	55°C				7584	9363	11301	13437	15808	18453
	P					6624	6719	6773	6787	6764	6706
	Q	50°C			6962	8657	10533	12627	14977	17621	20597
	P				5855	5961	6032	6069	6074	6049	5997
	Q	45°C		6208	7758	9509	11499	13766	16347	19282	22608
	P			5156	5264	5343	5394	5419	5419	5398	5356
	Q	40°C	5462	6804	8368	10192	12314	14771	17602	20844	24537
	P		4534	4637	4715	4771	4807	4824	4825	4812	4786
	Q	35°C	5935	7250	8845	10759	13030	15695	18793	22361	26438
	P		4086	4155	4209	4247	4272	4287	4293	4292	4286
	Q	30°C	6292	7597	9242	11264	13701	16592	19974	23885	28365
	P		3672	3714	3746	3771	3791	3808	3823	3840	3859
	Q	25°C	6587	7900	9611	11758	14380	17514	21198	25470	
	P		3295	3313	3329	3346	3365	3389	3419	3457	
	Q	20°C	6873	8211	10006	12296	15120	18514	22518		
	P		2955	2954	2959	2972	2995	3031	3080		
	Q	15°C	7202	8583	10480	12931	15973	19646			
	P		2654	2639	2637	2651	2683	2735			
Q	10°C	7628	9070	11086	13715	16994					
P		2393	2368	2365	2385	2431					
WB58KE-TFD-GN1	Q	60°C				7332	9331	11449	13729	16217	18957
	P					8619	8766	8854	8888	8868	8798
	Q	55°C				8918	11010	13290	15801	18589	21699
	P					7789	7901	7964	7981	7954	7886
	Q	50°C			8186	10180	12386	14848	17612	20721	24221
	P				6885	7010	7093	7136	7142	7113	7052
	Q	45°C		7300	9123	11182	13522	16187	19223	22674	26585
	P			6063	6191	6283	6343	6372	6373	6347	6299
	Q	40°C	6423	8002	9841	11985	14480	17369	20698	24511	28854
	P		5331	5452	5545	5611	5653	5674	5658	5628	
	Q	35°C	6979	8525	10401	12652	15322	18456	22099	26295	31089
	P		4804	4887	4949	4994	5024	5041	5048	5047	5040
	Q	30°C	7399	8934	10868	13245	16111	19511	23488	28088	33355
	P		4318	4367	4405	4434	4458	4478	4496	4516	4538
	Q	25°C	7746	9290	11302	13827	16910	20595	24927	29951	
	P		3875	3896	3915	3934	3957	3985	4020	4066	
	Q	20°C	8082	9656	11767	14460	17780	21771	26479		
	P		3475	3474	3479	3495	3522	3564	3622		
	Q	15°C	8469	10093	12324	15206	18784	23102			
	P		3121	3103	3101	3118	3155	3216			
Q	10°C	8970	10665	13036	16127	19984					
P		2814	2785	2781	2805	2858					

注: 1. 测试条件: 吸气温度20°C, 过冷度0°C
2. Q--制冷量 (W) P--功率 (W)

Note: 1. Test conditions: R.G. 20°C, subcooling 0°C
2. Q--Capacity(W) P--Power(W)

中温冷藏应用 WB Medium Temperature Refrigeration

制冷量-R404A

Cooling Capacity - R404A

制冷量 COOLING CAPACITY

型号 Model	项目 Item (W)	Tc\Te	-30°C	-25°C	-20°C	-15°C	-10°C	-5°C	0°C	5°C	10°C
WB76KE-TFD-GN1	Q	60°C				9554	12160	14920	17891	21133	24704
	P					11232	11423	11538	11582	11557	11466
	Q	55°C				11621	14348	17318	20591	24225	28277
	P					10151	10296	10379	10401	10366	10276
	Q	50°C			10668	13266	16141	19350	22951	27003	31563
	P				8972	9135	9243	9300	9307	9270	9190
	Q	45°C		9513	11889	14572	17621	21095	25051	29548	34644
	P			7901	8067	8188	8266	8303	8304	8272	8208
	Q	40°C	8370	10427	12824	15618	18869	22635	26973	31942	37601
	P		6947	7105	7226	7312	7366	7393	7394	7373	7334
	Q	35°C	9095	11110	13555	16488	19967	24051	28798	34266	40514
	P		6261	6368	6449	6508	6547	6569	6578	6577	6568
	Q	30°C	9643	11642	14162	17261	20995	25425	30608	36602	43466
	P		5627	5691	5740	5779	5809	5835	5859	5884	5914
	Q	25°C	10095	12106	14728	18019	22036	26838	32484	39031	
	P		5049	5076	5101	5127	5156	5193	5239	5298	
	Q	20°C	10532	12583	15334	18843	23170	28371	34506		
	P		4528	4527	4534	4554	4590	4644	4720		
	Q	15°C	11037	13153	16060	19815	24478	30106			
	P		4067	4043	4041	4063	4112	4191			
Q	10°C	11690	13898	16988	21016	26042					
P		3667	3629	3624	3655	3725					
WB89KE-TFD-GN1	Q	60°C				11015	14019	17200	20626	24364	28481
	P					12950	13169	13302	13353	13323	13218
	Q	55°C				13398	16541	19966	23739	27928	32600
	P					11702	11870	11965	11991	11950	11847
	Q	50°C			12299	15294	18608	22308	26459	31130	36388
	P				10344	10532	10656	10721	10730	10687	10595
	Q	45°C		10968	13706	16799	20315	24319	28880	34065	39940
	P			9108	9301	9440	9529	9573	9574	9536	9463
	Q	40°C	9650	12021	14784	18006	21754	26095	31096	36825	43349
	P		8009	8191	8330	8429	8492	8523	8524	8500	8455
	Q	35°C	10485	12808	15627	19008	23019	27728	33201	39505	46708
	P		7218	7341	7435	7503	7547	7573	7584	7582	7572
	Q	30°C	11117	13422	16327	19899	24205	29312	35287	42198	50111
	P		6488	6561	6618	6662	6697	6727	6755	6784	6818
	Q	25°C	11638	13957	16980	20773	25405	30941	37449	44997	
	P		5821	5852	5881	5911	5945	5986	6040	6108	
	Q	20°C	12142	14506	17678	21724	26712	32708	39781		
	P		5220	5219	5227	5250	5291	5354	5441		
	Q	15°C	12724	15164	18515	22844	28220	34708			
	P		4688	4662	4659	4684	4741	4832			
Q	10°C	13477	16023	19585	24229	30023					
P		4227	4184	4178	4214	4294					

注: 1. 测试条件: 吸气温度20°C, 过冷度0°C
2. Q--制冷量 (W) P--功率 (W)

Note: 1. Test conditions: R.G. 20°C, subcooling 0°C
2. Q--Capacity(W) P--Power(W)

制冷量-R404A

Cooling Capacity - R404A

WB 中温冷藏应用

Medium Temperature Refrigeration

制冷量 COOLING CAPACITY

型号 Model	项目 Item (W)	Tc\Te	-30°C	-25°C	-20°C	-15°C	-10°C	-5°C	0°C	5°C	10°C
WB110KE-TFD-GN1	Q	60°C				14369	18288	22438	26907	31783	37153
	P					16893	17179	17353	17419	17380	17244
	Q	55°C				17477	21578	26045	30968	36432	42527
	P					15266	15485	15609	15642	15589	15455
	Q	50°C			16044	19952	24275	29100	34516	40610	47469
	P				13494	13739	13901	13986	13998	13941	13821
	Q	45°C		14307	17880	21915	26501	31725	37675	44438	52102
	P			11882	12133	12314	12431	12488	12489	12440	12344
	Q	40°C	12588	15682	19286	23489	28378	34041	40565	48039	56549
	P		10448	10686	10867	10996	11078	11118	11120	11089	11029
	Q	35°C	13678	16708	20385	24796	30029	36171	43310	51534	60930
	P		9416	9577	9699	9787	9846	9879	9893	9891	9878
	Q	30°C	14502	17509	21299	25959	31576	38238	46032	55047	65370
	P		8463	8559	8633	8691	8737	8775	8812	8850	8895
	Q	25°C	15181	18207	22150	27099	33140	40363	48853	58699	
	P		7594	7635	7672	7711	7755	7809	7879	7968	
	Q	20°C	15840	18923	23061	28339	34845	42668	51895		
	P		6810	6808	6819	6849	6903	6984	7098		
	Q	15°C	16599	19781	24153	29801	36813	45277			
	P		6116	6081	6078	6110	6184	6303			
Q	10°C	17580	20902	25549	31607	39165					
P		5515	5458	5451	5497	5602					
WB150KE-TWD-GN1	Q	60°C				18762	23879	29298	35134	41501	48512
	P					22058	22432	22659	22744	22694	22516
	Q	55°C				22821	28175	34009	40436	47571	55529
	P					19933	20219	20381	20424	20355	20180
	Q	50°C			20949	26052	31697	37998	45069	53026	61982
	P				17620	17939	18151	18262	18277	18203	18046
	Q	45°C		18682	23346	28615	34603	41424	49193	58025	68032
	P			15515	15842	16079	16232	16306	16308	16243	16119
	Q	40°C	16437	20476	25183	30671	37055	44449	52968	62726	73838
	P		13643	13953	14189	14358	14465	14517	14520	14479	14401
	Q	35°C	17860	21817	26618	32377	39210	47230	56552	67291	79559
	P		12295	12505	12665	12779	12856	12900	12918	12915	12898
	Q	30°C	18935	22863	27811	33895	41230	49929	60106	71877	85356
	P		11051	11176	11273	11348	11408	11458	11506	11555	11614
	Q	25°C	19823	23774	28923	35384	43273	52703	63790	76646	
	P		9915	9969	10018	10068	10126	10197	10288	10404	
	Q	20°C	20683	24709	30111	37003	45499	55714	67762		
	P		8892	8889	8904	8943	9013	9120	9269		
	Q	15°C	21674	25829	31537	38912	48068	59120			
	P		7986	7940	7936	7979	8075	8231			
Q	10°C	22956	27293	33360	41271	51140					
P		7201	7127	7117	7178	7315					

注: 1. 测试条件: 吸气温度20°C, 过冷度0°C
2. Q--制冷量 (W) P--功率 (W)

Note: 1. Test conditions: R.G. 20°C, subcooling 0°C
2. Q--Capacity(W) P--Power(W)

中温冷藏应用

Medium Temperature Refrigeration

WB

制冷量-R404A

Cooling Capacity - R404A

制冷量 COOLING CAPACITY

型号 Model	项目 Item (W)	Tc\Te	-30°C	-25°C	-20°C	-15°C	-10°C	-5°C	0°C	5°C	10°C
WB190KE-TWD-GN1	Q	60°C				23092	29390	36059	43242	51078	59708
	P					27148	27608	27888	27993	27932	27712
	Q	55°C				28087	34677	41857	49767	58549	68343
	P					24533	24885	25084	25137	25053	24837
	Q	50°C			25783	32064	39011	46766	55470	65263	76286
	P				21686	22079	22340	22476	22495	22404	22211
	Q	45°C		22993	28734	35219	42589	50984	60546	71415	83732
	P			19095	19498	19790	19978	20069	20071	19992	19838
	Q	40°C	20230	25202	30994	37748	45606	54706	65191	77201	90878
	P		16791	17173	17464	17671	17803	17867	17870	17820	17725
	Q	35°C	21982	26851	32760	39849	48259	58130	69603	82819	97919
	P		15132	15391	15587	15729	15823	15877	15899	15895	15875
	Q	30°C	23305	28139	34229	41717	50744	61451	73977	88465	105054
	P		13601	13755	13874	13967	14041	14103	14161	14222	14294
	Q	25°C	24398	29260	35597	43550	53259	64866	78510	94334	
	P		12203	12269	12330	12391	12462	12550	12662	12806	
	Q	20°C	25456	30411	37060	45542	55999	68571	83399		
	P		10944	10940	10959	11007	11093	11224	11408		
	Q	15°C	26675	31790	38815	47892	59161	72763			
	P		9829	9773	9767	9820	9938	10130			
Q	10°C	28253	33591	41058	50795	62941					
P		8862	8771	8760	8834	9003					

注: 1. 测试条件: 吸气温度20°C, 过冷度0°C
2. Q--制冷量 (W) P--功率 (W)

Note: 1. Test conditions: R.G. 20°C, subcooling 0°C
2. Q--Capacity(W) P--Power(W)

制冷量-R22

Cooling Capacity - R22

WF 低温冷冻应用

Low Temperature Freezing

制冷量 COOLING CAPACITY

型号 Model	项目 Item (W)	Tc\Te	-40°C	-35°C	-30°C	-25°C	-20°C	-15°C	-10°C	-5°C	0°C
WF06KE-PFJ-GL1	Q	60°C						2668	3220	3858	4593
	P						2132	2221	2322	2441	
	Q	55°C	982	1250	1563	1930	2359	2861	3444	4117	4890
	P		1580	1682	1769	1845	1919	1994	1994	2078	2176
	Q	50°C	1052	1334	1664	2051	2504	3033	3646	4353	5163
	P		1495	1582	1656	1722	1787	1857	1938	2035	2155
	Q	45°C	1111	1405	1751	2157	2633	3187	3830	4569	5415
	P		1406	1479	1542	1599	1657	1722	1801	1898	2020
	Q	40°C	1162	1467	1828	2252	2749	3328	3998	4769	5649
	P		1313	1375	1427	1477	1530	1592	1669	1768	1894
	Q	35°C	1208	1524	1897	2338	2856	3458	4156	4956	5870
	P		1220	1270	1314	1358	1407	1467	1545	1647	1778
	Q	30°C	1253	1578	1964	2421	2957	3582	4305	5135	6081
	P		1126	1167	1204	1243	1289	1350	1430	1536	1674
	Q	25°C	1302	1634	2031	2503	3057	3703	4450	5308	6285
	P		1035	1068	1099	1135	1180	1241	1325	1437	1583
	Q	20°C	1356	1695	2103	2587	3158	3824	4595	5480	6487
	P		948	974	1001	1034	1080	1144	1232	1351	1507
Q	15°C	1420	1765	2181	2678	3265	3950	4743	5653		
P		866	887	911	944	991	1059	1154	1281		
Q	10°C	1498	1847	2271	2779	3380	4083	4897			
P		791	809	831	865	915	988	1091			
WF09KE-PFJ-GL1	Q	60°C						3629	4380	5248	6247
	P						2815	2933	3066	3224	
	Q	55°C	1335	1700	2126	2625	3209	3892	4685	5601	6652
	P		2086	2221	2336	2437	2534	2633	2744	2874	3031
	Q	50°C	1431	1814	2263	2790	3406	4126	4960	5921	7022
	P		1974	2090	2187	2275	2360	2452	2559	2687	2845
	Q	45°C	1511	1911	2382	2934	3581	4336	5209	6215	7365
	P		1856	1953	2036	2112	2189	2275	2378	2507	2668
	Q	40°C	1580	1996	2486	3063	3739	4527	5439	6487	7684
	P		1734	1815	1885	1950	2020	2102	2205	2335	2502
	Q	35°C	1643	2073	2581	3181	3884	4704	5653	6742	7984
	P		1611	1677	1735	1793	1857	1937	2041	2175	2349
	Q	30°C	1705	2147	2672	3293	4022	4873	5856	6985	8271
	P		1487	1542	1590	1641	1703	1782	1888	2028	2211
	Q	25°C	1770	2223	2763	3404	4158	5037	6054	7220	8549
	P		1367	1411	1452	1498	1558	1639	1750	1898	2091
	Q	20°C	1844	2306	2860	3519	4296	5202	6250	7453	8823
	P		1252	1287	1322	1366	1426	1511	1627	1785	1990
Q	15°C	1932	2401	2967	3643	4441	5373	6451	7689		
P		1144	1172	1203	1246	1309	1398	1524	1692		
Q	10°C	2038	2513	3090	3781	4598	5554	6662			
P		1045	1068	1098	1142	1208	1305	1440			

注: 1. 测试条件: 回气温度20°C, 过冷度0°C
2. Q--制冷量 (W) P--功率 (W)

Note: 1. Test conditions: R.G. 20°C, subcooling 0°C
2. Q--Capacity(W) P--Power(W)

低温冷冻应用

Low Temperature Freezing

WF

制冷量-R22

Cooling Capacity - R22

制冷量 COOLING CAPACITY

型号 Model	项目 Item (W)	Tc\Te	-40°C	-35°C	-30°C	-25°C	-20°C	-15°C	-10°C	-5°C	0°C
WF13KE-PFJ-GL1	Q	60°C						4583	5531	6628	7890
	P						3555	3703	3872	4071	
	Q	55°C	1686	2147	2684	3314	4053	4915	5916	7073	8400
	P		2635	2805	2950	3078	3200	3326	3466	3630	3828
	Q	50°C	1807	2291	2858	3523	4302	5210	6263	7478	8868
	P		2493	2639	2762	2873	2981	3097	3231	3393	3593
	Q	45°C	1908	2414	3008	3705	4523	5475	6579	7849	9301
	P		2344	2467	2571	2667	2764	2873	3003	3165	3369
	Q	40°C	1996	2520	3139	3868	4722	5717	6868	8192	9704
	P		2190	2292	2380	2463	2551	2655	2784	2949	3159
	Q	35°C	2075	2617	3259	4017	4905	5941	7138	8514	10083
	P		2034	2118	2192	2264	2346	2447	2577	2747	2966
	Q	30°C	2153	2711	3374	4158	5080	6153	7395	8821	10445
	P		1878	1947	2008	2073	2150	2251	2384	2562	2792
	Q	25°C	2236	2807	3489	4299	5251	6361	7645	9118	10796
	P		1726	1782	1834	1892	1968	2070	2210	2396	2640
	Q	20°C	2329	2912	3612	4444	5425	6569	7893	9413	11143
	P		1581	1625	1670	1725	1801	1908	2055	2254	2513
Q	15°C	2440	3032	3747	4600	5608	6785	8147	9710		
P		1444	1480	1520	1574	1653	1766	1924	2137		
Q	10°C	2573	3173	3902	4774	5806	7014	8413			
P		1320	1349	1386	1442	1526	1648	1819			
WF06KE-TFD-GL1	Q	60°C						2668	3220	3858	4593
	P						2070	2156	2254	2370	
	Q	55°C	982	1250	1563	1930	2359	2861	3444	4117	4890
	P		1534	1633	1717	1792	1863	1936	2018	2113	2229
	Q	50°C	1052	1334	1664	2051	2504	3033	3646	4353	5163
	P		1451	1536	1608	1672	1735	1803	1881	1975	2092
	Q	45°C	1111	1405	1751	2157	2633	3187	3830	4569	5415
	P		1365	1436	1497	1552	1609	1672	1748	1843	1962
	Q	40°C	1162	1467	1828	2252	2749	3328	3998	4769	5649
	P		1275	1335	1386	1434	1485	1546	1621	1717	1839
	Q	35°C	1208	1524	1897	2338	2856	3458	4156	4956	5870
	P		1184	1233	1276	1318	1366	1424	1500	1599	1727
	Q	30°C	1253	1578	1964	2421	2957	3582	4305	5135	6081
	P		1094	1133	1169	1207	1252	1310	1388	1491	1625
	Q	25°C	1302	1634	2031	2503	3057	3703	4450	5308	6285
	P		1005	1037	1067	1102	1146	1205	1286	1395	1537
	Q	20°C	1356	1695	2103	2587	3158	3824	4595	5480	6487
	P		920	946	972	1004	1048	1111	1196	1312	1463
Q	15°C	1420	1765	2181	2678	3265	3950	4743	5653		
P		841	861	885	916	962	1028	1120	1244		
Q	10°C	1498	1847	2271	2779	3380	4083	4897			
P		768	785	807	839	888	959	1059			

注: 1. 测试条件: 回气温度20°C, 过冷度0°C
2. Q--制冷量 (W) P--功率 (W)

Note: 1. Test conditions: R.G. 20°C, subcooling 0°C
2. Q--Capacity(W) P--Power(W)

制冷量-R22

Cooling Capacity - R22

WF 低温冷冻应用

Low Temperature Freezing

制冷量 COOLING CAPACITY

型号 Model	项目 Item (W)	Tc\Te	-40°C	-35°C	-30°C	-25°C	-20°C	-15°C	-10°C	-5°C	0°C
WF09KE-TFD-GL1	Q	60°C						3629	4380	5248	6247
	P							2733	2847	2977	3130
	Q	55°C	1335	1700	2126	2625	3209	3892	4685	5601	6652
	P		2025	2157	2268	2366	2460	2557	2664	2791	2943
	Q	50°C	1431	1814	2263	2790	3406	4126	4960	5921	7022
	P		1917	2029	2123	2208	2292	2381	2484	2609	2763
	Q	45°C	1511	1911	2382	2934	3581	4336	5209	6215	7365
	P		1802	1897	1977	2050	2125	2208	2309	2434	2590
	Q	40°C	1580	1996	2486	3063	3739	4527	5439	6487	7684
	P		1684	1762	1830	1893	1961	2041	2140	2267	2429
	Q	35°C	1643	2073	2581	3181	3884	4704	5653	6742	7984
	P		1564	1628	1685	1741	1803	1881	1981	2112	2280
	Q	30°C	1705	2147	2672	3293	4022	4873	5856	6985	8271
	P		1444	1497	1544	1594	1653	1730	1833	1969	2146
	Q	25°C	1770	2223	2763	3404	4158	5037	6054	7220	8549
	P		1327	1370	1410	1455	1513	1592	1699	1842	2030
	Q	20°C	1844	2306	2860	3519	4296	5202	6250	7453	8823
	P		1215	1249	1284	1326	1385	1467	1580	1733	1932
	Q	15°C	1932	2401	2967	3643	4441	5373	6451	7689	
	P		1110	1138	1168	1210	1270	1358	1479	1643	
Q	10°C	2038	2513	3090	3781	4598	5554	6662			
P		1015	1037	1066	1108	1173	1267	1398			
WF13KE-TFD-GL1	Q	60°C						4583	5531	6628	7890
	P							3452	3596	3759	3952
	Q	55°C	1686	2147	2684	3314	4053	4915	5916	7073	8400
	P		2558	2723	2864	2988	3106	3229	3365	3524	3717
	Q	50°C	1807	2291	2858	3523	4302	5210	6263	7478	8868
	P		2421	2562	2681	2789	2894	3007	3137	3294	3489
	Q	45°C	1908	2414	3008	3705	4523	5475	6579	7849	9301
	P		2276	2395	2496	2589	2683	2789	2916	3073	3271
	Q	40°C	1996	2520	3139	3868	4722	5717	6868	8192	9704
	P		2126	2226	2311	2391	2477	2577	2703	2863	3067
	Q	35°C	2075	2617	3259	4017	4905	5941	7138	8514	10083
	P		1975	2057	2128	2198	2277	2375	2502	2667	2880
	Q	30°C	2153	2711	3374	4158	5080	6153	7395	8821	10445
	P		1824	1890	1950	2012	2088	2185	2315	2487	2711
	Q	25°C	2236	2807	3489	4299	5251	6361	7645	9118	10796
	P		1676	1730	1780	1837	1910	2010	2145	2326	2563
	Q	20°C	2329	2912	3612	4444	5425	6569	7893	9413	11143
	P		1535	1578	1621	1675	1748	1852	1995	2188	2440
	Q	15°C	2440	3032	3747	4600	5608	6785	8147	9710	
	P		1402	1437	1475	1528	1604	1714	1868	2075	
Q	10°C	2573	3173	3902	4774	5806	7014	8413			
P		1281	1310	1346	1400	1481	1600	1766			

注: 1. 测试条件: 回气温度20°C, 过冷度0°C
2. Q--制冷量 (W) P--功率 (W)

Note: 1. Test conditions: R.G. 20°C, subcooling 0°C
2. Q--Capacity(W) P--Power(W)

低温冷冻应用

Low Temperature Freezing

WF

制冷量-R22

Cooling Capacity - R22

制冷量 COOLING CAPACITY

型号 Model	项目 Item (W)	Tc\Te	-40°C	-35°C	-30°C	-25°C	-20°C	-15°C	-10°C	-5°C	0°C
WF15KE-TFD-GL1	Q	60°C						6061	7314	8764	10433
	P							4564	4755	4971	5227
	Q	55°C	2230	2839	3550	4383	5359	6499	7823	9353	11108
	P		3382	3601	3787	3951	4108	4270	4449	4660	4915
	Q	50°C	2390	3030	3779	4659	5688	6890	8283	9888	11727
	P		3201	3388	3546	3688	3827	3976	4148	4356	4613
	Q	45°C	2524	3192	3977	4900	5981	7240	8700	10379	12299
	P		3010	3167	3301	3424	3548	3688	3856	4064	4326
	Q	40°C	2639	3333	4151	5115	6244	7560	9082	10833	12832
	P		2812	2943	3056	3162	3275	3408	3574	3786	4056
	Q	35°C	2744	3461	4310	5312	6487	7856	9440	11259	13334
	P		2611	2720	2814	2907	3011	3141	3308	3526	3808
	Q	30°C	2847	3585	4462	5499	6717	8137	9779	11664	13813
	P		2412	2500	2579	2661	2761	2890	3061	3289	3584
	Q	25°C	2956	3712	4614	5685	6943	8411	10109	12057	14277
	P		2217	2287	2354	2429	2526	2658	2837	3077	3390
	Q	20°C	3080	3851	4776	5877	7173	8687	10438	12447	14735
	P		2030	2086	2144	2215	2312	2449	2639	2894	3227
	Q	15°C	3226	4009	4955	6084	7416	8972	10774	12841	
	P		1854	1900	1951	2021	2122	2267	2470	2743	
Q	10°C	3403	4196	5160	6313	7678	9275	11125			
P		1695	1732	1780	1851	1959	2116	2335			
WF18KE-TFD-GL1	Q	60°C						7094	8560	10258	12211
	P							5342	5565	5818	6117
	Q	55°C	2610	3323	4155	5130	6272	7607	9157	10947	13001
	P		3959	4215	4432	4625	4808	4997	5208	5454	5752
	Q	50°C	2797	3546	4423	5452	6658	8064	9694	11573	13726
	P		3746	3965	4150	4316	4479	4654	4855	5099	5400
	Q	45°C	2954	3736	4655	5735	7000	8474	10182	12148	14395
	P		3522	3707	3863	4007	4153	4316	4513	4756	5063
	Q	40°C	3089	3901	4859	5986	7308	8848	10630	12679	15019
	P		3291	3445	3576	3701	3833	3989	4183	4431	4748
	Q	35°C	3212	4051	5045	6217	7592	9195	11048	13177	15606
	P		3056	3183	3293	3402	3525	3676	3872	4127	4457
	Q	30°C	3332	4196	5222	6436	7862	9524	11446	13652	16167
	P		2823	2926	3018	3115	3231	3382	3583	3849	4195
	Q	25°C	3460	4344	5401	6653	8127	9845	11832	14112	16710
	P		2594	2677	2755	2843	2957	3111	3320	3601	3967
	Q	20°C	3605	4507	5590	6878	8396	10167	12217	14568	17246
	P		2375	2442	2509	2592	2706	2866	3088	3387	3777
	Q	15°C	3776	4693	5799	7120	8679	10501	12610	15029	
	P		2170	2224	2283	2365	2483	2654	2891	3211	
Q	10°C	3983	4911	6039	7389	8987	10856	13020			
P		1983	2027	2083	2166	2292	2476	2733			

注: 1. 测试条件: 回气温度20°C, 过冷度0°C
2. Q--制冷量 (W) P--功率 (W)

Note: 1. Test conditions: R.G. 20°C, subcooling 0°C
2. Q--Capacity(W) P--Power(W)

制冷量-R22

Cooling Capacity - R22

WF 低温冷冻应用

Low Temperature Freezing

制冷量 COOLING CAPACITY

		WF25KE-TFD-GL1									
型号 Model	项目 Item (W)	Tc/Te	-40°C	-35°C	-30°C	-25°C	-20°C	-15°C	-10°C	-5°C	0°C
Q	60°C										
			7747	9348	11202	13334					
P	60°C		5834	6077	6354	6680					
Q	55°C		2850	3628	4537	5602	6850	8307	9999	11954	14197
			4323	4603	4840	5050	5250	5457	5687	5956	6282
P	55°C		3055	3873	4830	5954	7270	8806	10586	12638	14989
			4091	4330	4532	4714	4891	5082	5302	5568	5896
Q	50°C		3225	4080	5083	6262	7644	9254	11119	13265	15720
			3847	4048	4219	4376	4535	4714	4928	5194	5529
P	50°C		3373	4260	5306	6537	7981	9662	11608	13846	16401
			3594	3762	3905	4041	4186	4356	4568	4839	5184
Q	45°C		3507	4424	5509	6789	8291	10041	12065	14390	17042
			3337	3476	3596	3715	3849	4015	4228	4507	4867
P	45°C		3639	4582	5703	7028	8585	10400	12499	14908	17654
			3082	3195	3296	3401	3528	3693	3913	4203	4581
Q	40°C		3779	4744	5898	7266	8874	10751	12921	15411	18247
			2833	2924	3009	3105	3229	3397	3626	3932	4332
P	40°C		3937	4922	6104	7511	9168	11103	13341	15909	18833
			2594	2666	2740	2830	2955	3130	3372	3698	4124
Q	35°C		4123	5124	6333	7775	9478	11467	13770	16412	
			2370	2428	2494	2583	2712	2898	3157	3506	
P	35°C		4349	5363	6594	8069	9814	11855	14218		
			2166	2214	2275	2366	2503	2704	2984		
Q	30°C										
P	30°C										
Q	25°C										
P	25°C										
Q	20°C										
P	20°C										
Q	15°C										
P	15°C										
Q	10°C										
P	10°C										
Q	60°C										
			9109	10993	13173	15680					
P	60°C		6860	7146	7471	7855					
Q	55°C		3351	4267	5335	6587	8055	9768	11758	14057	16695
			5084	5413	5691	5939	6174	6417	6687	7004	7387
P	55°C		3592	4554	5680	7002	8549	10355	12448	14862	17626
			4811	5092	5329	5543	5752	5976	6235	6548	6934
Q	50°C		3793	4797	5977	7364	8989	10882	13075	15599	18485
			4523	4760	4961	5146	5333	5543	5795	6108	6502
P	50°C		3966	5009	6239	7687	9385	11362	13651	16282	19286
			4226	4424	4593	4752	4923	5123	5372	5690	6096
Q	45°C		4124	5202	6478	7983	9749	11807	14187	16921	20040
			3925	4087	4229	4369	4526	4721	4972	5300	5723
P	45°C		4279	5388	6706	8265	10096	12230	14698	17531	20760
			3625	3757	3875	4000	4149	4343	4601	4943	5387
Q	40°C		4443	5579	6935	8544	10436	12642	15194	18122	21458
			3331	3438	3538	3651	3797	3995	4264	4624	5094
P	40°C		4629	5787	7178	8832	10781	13056	15688	18707	22146
			3050	3136	3222	3328	3475	3681	3966	4349	4850
Q	35°C		4849	6026	7447	9143	11146	13485	16192	19299	
			2787	2855	2932	3037	3189	3408	3712	4123	
P	35°C		5115	6307	7755	9489	11540	13940	16720		
			2547	2603	2675	2782	2944	3180	3509		

注: 1. 测试条件: 回气温度20°C, 过冷度0°C
2. Q--制冷量 (W) P--功率 (W)

Note: 1. Test conditions: R.G. 20°C, subcooling 0°C
2. Q--Capacity(W) P--Power(W)

低温冷冻应用

Low Temperature Freezing

WF

制冷量-R22

Cooling Capacity - R22

制冷量 COOLING CAPACITY

		WF34KE-TFD-GL1									
型号 Model	项目 Item (W)	Tc/Te	-40°C	-35°C	-30°C	-25°C	-20°C	-15°C	-10°C	-5°C	0°C
Q	60°C										
P	60°C										
Q	55°C		4367	5560	6952	8584	10496	12729	15323	18318	21756
			6625	7054	7417	7739	8046	8362	8714	9127	9626
P	55°C		4681	5934	7402	9124	11141	13494	16222	19367	22969
			6269	6635	6945	7223	7496	7788	8125	8532	9036
Q	50°C		4943	6252	7789	9597	11713	14181	17039	20328	24089
			5894	6203	6465	6705	6950	7223	7551	7959	8473
P	50°C		5169	6528	8131	10018	12229	14806	17789	21217	25132
			5507	5765	5985	6193	6415	6676	7001	7415	7945
Q	45°C		5374	6779	8442	10404	12705	15386	18488	22051	26115
			5114	5326	5511	5693	5898	6152	6480	6907	7458
P	45°C		5576	7021	8739	10770	13156	15937	19153	22845	27053
			4723	4896	5050	5212	5407	5660	5996	6441	7020
Q	40°C		5790	7270	9037	11134	13599	16474	19800	23616	27963
			4341	4480	4611	4758	4948	5206	5556	6026	6639
P	40°C		6032	7542	9354	11510	14050	17014	20444	24378	28859
			3975	4086	4198	4337	4528	4797	5168	5667	6320
Q	35°C		6319	7853	9705	11915	14524	17573	21101	25150	
			3632	3721	3821	3957	4155	4441	4838	5373	
P	35°C		6665	8219	10105	12365	15038	18166	21788		
			3319	3392	3486	3625	3836				
Q	30°C										
P	30°C										
Q	25°C										
P	25°C										
Q	20°C										
P	20°C										
Q	15°C										
P	15°C										
Q	10°C										
P	10°C										
Q	60°C										
P	60°C										
Q	55°C		5035	6410	8015	9897	12101	14675	17665	21119	25081
			7637	8132	8550	8922	9276	9641	10047	10522	11098
P	55°C		5396	6842	8534	10519	12844	15556	18702	22328	26480
			7228	7650	8006	8327	8642	8978	9367	9837	10417
Q	50°C		5698	7207	8980	11064	13504	16348	19643	23435	27771
			6795	7151	7453	7731	8012</				

制冷量-R22

Cooling Capacity - R22

WF 低温冷冻应用

Low Temperature Freezing

制冷量 COOLING CAPACITY

型号 Model	项目 Item (W)	Tc\Te	-40°C	-35°C	-30°C	-25°C	-20°C	-15°C	-10°C	-5°C	0°C
WF49KE-TFD-GL1	Q	60°C						17853	21544	25816	30731
	P							13445	14005	14643	15396
	Q	55°C	6568	8362	10456	12910	15786	19144	23044	27549	32719
	P		9963	10608	11154	11639	12100	12576	13106	13727	14477
	Q	50°C	7040	8925	11132	13722	16755	20293	24397	29126	34543
	P		9429	9979	10444	10863	11273	11712	12219	12832	13589
	Q	45°C	7433	9402	11715	14433	17616	21327	25625	30572	36228
	P		8865	9329	9723	10085	10452	10863	11357	11970	12742
	Q	40°C	7773	9817	12228	15066	18392	22268	26753	31909	37797
	P		8282	8669	9001	9314	9648	10040	10528	11152	11948
	Q	35°C	8083	10195	12696	15646	19107	23140	27805	33163	39275
	P		7692	8010	8288	8562	8871	9252	9745	10387	11216
	Q	30°C	8386	10559	13142	16198	19786	23968	28805	34357	40686
	P		7104	7363	7595	7839	8132	8512	9017	9687	10558
	Q	25°C	8708	10933	13592	16744	20452	24776	29777	35516	42054
	P		6529	6738	6934	7156	7441	7829	8356	9062	9984
	Q	20°C	9072	11342	14068	17310	21130	25588	30746	36663	43402
	P		5978	6145	6314	6523	6810	7214	7772	8523	9505
	Q	15°C	9503	11810	14595	17919	21843	26428	31735	37824	
	P		5462	5596	5747	5952	6250	6678	7276	8081	
Q	10°C	10024	12361	15198	18596	22617	27320	32768			
P		4991	5101	5242	5452	5769	6232	6878			
WF60KE-TWD-GL1	Q	60°C						23312	28131	33709	40127
	P							17555	18287	19120	20103
	Q	55°C	8576	10919	13653	16858	20612	24997	30090	35972	42722
	P		13009	13852	14565	15197	15800	16422	17113	17923	18903
	Q	50°C	9192	11654	14536	17917	21878	26498	31856	38032	45105
	P		12311	13030	13638	14184	14720	15293	15955	16756	17744
	Q	45°C	9706	12277	15296	18845	23002	27847	33460	39919	47305
	P		11575	12181	12696	13168	13648	14185	14829	15630	16638
	Q	40°C	10150	12819	15967	19672	24015	29076	34933	41665	49354
	P		10814	11320	11752	12162	12597	13109	13747	14561	15601
	Q	35°C	10554	13312	16577	20430	24949	30215	36306	43303	51284
	P		10043	10460	10822	11180	11583	12081	12724	13563	14646
	Q	30°C	10951	13787	17160	21150	25836	31296	37612	44862	53126
	P		9275	9614	9918	10236	10618	11114	11774	12649	13786
	Q	25°C	11371	14276	17747	21864	26705	32351	38881	46375	54911
	P		8525	8798	9054	9344	9716	10222	10911	11833	13037
	Q	20°C	11846	14810	18369	22603	27590	33412	40146	47873	56672
	P		7806	8024	8245	8518	8893	9420	10149	11129	12411
	Q	15°C	12408	15421	19058	23398	28522	34509	41437	49388	
	P		7132	7307	7504	7771	8160	8720	9500	10551	
Q	10°C	13089	16140	19844	24282	29532	35674	42787			
P		6517	6661	6845	7119	7533	8137				

注: 1. 测试条件: 回气温度20°C, 过冷度0°C
2. Q--制冷量 (W) P--功率 (W)

Note: 1. Test conditions: R.G. 20°C, subcooling 0°C
2. Q--Capacity(W) P--Power(W)

低温冷冻应用

Low Temperature Freezing

WF

制冷量-R22

Cooling Capacity - R22

制冷量 COOLING CAPACITY

型号 Model	项目 Item (W)	Tc\Te	-40°C	-35°C	-30°C	-25°C	-20°C	-15°C	-10°C	-5°C	0°C
WF75KE-TWD-GL1	Q	60°C						28691	34622	41488	49387
	P							21606	22508	23532	24742
	Q	55°C	10555	13438	16803	20748	25369	30765	37034	44274	52582
	P		16011	17048	17926	18704	19446	20211	21062	22060	23265
	Q	50°C	11313	14343	17890	22052	26927	32613	39207	46808	55513
	P		15152	16037	16785	17458	18116	18823	19637	20622	21838
	Q	45°C	11946	15110	18826	23194	28311	34274	41181	49131	58221
	P		14246	14993	15626	16207	16797	17458	18251	19237	20478
	Q	40°C	12492	15777	19651	24212	29558	35786	42994	51280	60743
	P		13310	13932	14465	14968	15504	16134	16920	17922	19201
	Q	35°C	12990	16384	20403	25145	30707	37188	44684	53295	63118
	P		12361	12873	13319	13759	14256	14869	15661	16693	18026
	Q	30°C	13478	16969	21120	26031	31798	38519	46292	55215	65385
	P		11416	11833	12206	12598	13068	13679	14492	15568	16968
	Q	25°C	13995	17570	21843	26909	32868	39817	47854	57077	67583
	P		10492	10828	11143	11500	11959	12581	13429	14563	16045
	Q	20°C	14580	18228	22608	27819	33957	41122	49411	58921	69750
	P		9607	9876	10147	10483	10945	11593	12491	13697	15275
	Q	15°C	15272	18980	23456	28798	35104	42472	51000	60785	
	P		8778	8993	9235	9565	10043	10732	11693	12986	
Q	10°C	16109	19864	24424	29885	36347	43906	52661			
P		8021	8198	8425	8762	9272	10015	11053			

注: 1. 测试条件: 回气温度20°C, 过冷度0°C
2. Q--制冷量 (W) P--功率 (W)

Note: 1. Test conditions: R.G. 20°C, subcooling 0°C
2. Q--Capacity(W) P--Power(W)

制冷量-R404A

Cooling Capacity - R404A

WF 低温冷冻应用

Low Temperature Freezing

制冷量 COOLING CAPACITY

型号 Model	项目 Item (W)	Tc/Te	-40°C	-35°C	-30°C	-25°C	-20°C	-15°C	-10°C	-5°C	0°C	
WF06KE-PFJ-GL1	Q	60°C							2238	2693	3258	3958
	P								2254	2356	2466	2589
	Q	55°C	930	1233	1529	1845	2204	2632	3154	3794	4579	
	P		1551	1684	1797	1898	1992	2084	2181	2289	2413	
	Q	50°C	1068	1392	1718	2072	2478	2962	3548	4261	5126	
	P		1443	1558	1656	1745	1830	1916	2009	2117	2243	
	Q	45°C	1167	1509	1862	2252	2702	3238	3886	4669	5614	
	P		1331	1430	1515	1594	1671	1752	1844	1953	2083	
	Q	40°C	1237	1595	1973	2395	2888	3474	4181	5031	6052	
	P		1220	1304	1378	1448	1519	1597	1689	1800	1936	
	Q	35°C	1292	1663	2063	2516	3047	3681	4444	5360	6454	
	P		1112	1183	1247	1310	1377	1454	1547	1662	1806	
	Q	30°C	1343	1725	2143	2624	3192	3871	4687	5666	6831	
	P		1011	1071	1126	1183	1247	1325	1421	1542	1695	
	Q	25°C	1402	1792	2227	2733	3334	4056	4924	5961	7195	
	P		920	970	1019	1072	1135	1214	1315	1444	1606	
	Q	20°C	1481	1876	2325	2854	3487	4248	5164	6259	7558	
	P		842	884	928	979	1042	1125	1232	1370	1544	
Q	15°C	1592	1990	2451	2999	3661	4460	5421	6571			
P		781	817	857	907	972	1060	1175	1323			
Q	10°C	1747	2145	2615	3181	3868	4702	5707				
P		740	771	809	859	929	1023	1147				
WF09KE-PFJ-GL1	Q	60°C						3044	3663	4432	5384	
	P							2976	3111	3256	3419	
	Q	55°C	1265	1677	2080	2509	2998	3580	4290	5161	6228	
	P		2048	2224	2374	2507	2630	2752	2880	3022	3186	
	Q	50°C	1453	1893	2337	2818	3371	4029	4826	5796	6973	
	P		1905	2057	2187	2305	2416	2530	2654	2795	2962	
	Q	45°C	1587	2052	2533	3063	3675	4405	5286	6351	7636	
	P		1758	1888	2001	2105	2207	2314	2436	2579	2751	
	Q	40°C	1683	2170	2684	3258	3928	4726	5686	6844	8232	
	P		1611	1722	1820	1912	2006	2109	2231	2377	2557	
	Q	35°C	1757	2262	2806	3422	4144	5007	6045	7290	8778	
	P		1468	1563	1647	1730	1818	1920	2043	2195	2384	
	Q	30°C	1827	2346	2916	3569	4341	5266	6376	7706	9291	
	P		1335	1414	1488	1563	1647	1750	1877	2037	2238	
	Q	25°C	1907	2437	3029	3717	4535	5517	6697	8109	9786	
	P		1215	1281	1346	1415	1499	1603	1737	1907	2121	
	Q	20°C	2014	2552	3163	3882	4743	5779	7024	8514	10281	
	P		1112	1168	1225	1292	1376	1485	1627	1809	2039	
Q	15°C	2166	2707	3334	4080	4979	6066	7374	8938			
P		1032	1079	1131	1197	1284	1399	1551	1748			
Q	10°C	2377	2918	3557	4327	5261	6395	7762				
P		977	1018	1068	1135	1227	1351	1515				

注: 1. 测试条件: 回气温度20°C, 过冷度0°C
2. Q--制冷量 (W) P--功率 (W)

Note: 1. Test conditions: R.G. 20°C, subcooling 0°C
2. Q--Capacity(W) P--Power(W)

低温冷冻应用

Low Temperature Freezing

WF

制冷量-R404A

Cooling Capacity - R404A

制冷量 COOLING CAPACITY

型号 Model	项目 Item (W)	Tc/Te	-40°C	-35°C	-30°C	-25°C	-20°C	-15°C	-10°C	-5°C	0°C	
WF13KE-PFJ-GL1	Q	60°C							3844	4626	5596	6799
	P								3759	3929	4112	4318
	Q	55°C	1597	2117	2627	3169	3786	4521	5418	6518	7865	
	P		2587	2808	2998	3165	3321	3475	3637	3817	4024	
	Q	50°C	1835	2391	2952	3559	4257	5087	6094	7319	8806	
	P		2406	2597	2762	2910	3051	3195	3351	3530	3741	
	Q	45°C	2004	2592	3199	3868	4641	5563	6675	8021	9643	
	P		2220	2385	2527	2658	2787	2922	3076	3256	3474	
	Q	40°C	2125	2740	3389	4115	4960	5968	7181	8643	10396	
	P		2034	2175	2298	2414	2533	2664	2817	3002	3229	
	Q	35°C	2219	2857	3543	4321	5234	6323	7633	9206	11086	
	P		1854	1973	2080	2184	2296	2424	2580	2772	3011	
	Q	30°C	2307	2963	3682	4508	5483	6650	8052	9732	11733	
	P		1686	1786	1879	1973	2080	2209	2370	2572	2826	
	Q	25°C	2408	3078	3825	4694	5728	6968	8458	10240	12359	
	P		1534	1618	1699	1788	1893	2025	2193	2408	2679	
	Q	20°C	2544	3223	3995	4902	5989	7298	8871	10752	12983	
	P		1404	1475	1548	1632	1738	1875	2054	2284	2575	
Q	15°C	2735	3418	4210	5152	6288	7660	9312	11287			
P		1303	1362	1429	1512	1621	1767	1959	2207			
Q	10°C	3002	3685	4492	5464	6644	8076	9803				
P		1234	1286	1349	1433	1549	1706	1913				
WF06KE-TFD-GL1	Q	60°C							2238	2693	3258	3958
	P								2188	2287	2394	2513
	Q	55°C	930	1233	1529	1845	2204	2632	3154	3794	4579	
	P		1506	1635	1745	1843	1934	2023	2117	2222	2343	
	Q	50°C	1068	1392	1718	2072	2478	2962	3548	4261	5126	
	P		1401	1512	1608	1694	1776	1860	1951	2055	2178	
	Q	45°C	1167	1509	1862	2252	2702	3238	3886	4669	5614	
	P		1292	1388	1471	1547	1622	1701	1791	1896	2023	
	Q	40°C	1237	1595	1973	2395	2888	3474	4181	5031	6052	
	P		1184	1266	1338	1405	1475	1551	1640	1748	1880	
	Q	35°C	1292	1663	2063	2516	3047	3681	4444	5360	6454	
	P		1079	1149	1211	1272	1336	1411	1502	1614	1753	
	Q	30°C	1343	1725	2143	2624	3192	3871	4687	5666	6831	
	P		981	1040	1094	1149	1211	1286	1380	1497	1645	
	Q	25°C	1402	1792	2227	2733	3334	4056	4924	5961	7195	
	P		893	942	989	1041	1102	1179	1277	1402	1560	
	Q	20°C	1481	1876	2325	2854	3487	4248	5164	6259	7558	
	P		818	859	901	950	1012	1092	1196	1330	1499	
Q	15°C	1592	1990	2451	2999	3661	4460	5421	6571			
P		758	793	832	880	944	1029	1141	1285			
Q	10°C	1747	2145	2615	3181	3868	4702	5707				
P		718	748	785	834	902	993	1114				

注: 1. 测试条件: 回气温度20°C, 过冷度0°C
2. Q--制冷量 (W) P--功率 (W)

Note: 1. Test conditions: R.G. 20°C, subcooling 0°C
2. Q--Capacity(W) P--Power(W)

制冷量-R404A

Cooling Capacity - R404A

WF 低温冷冻应用

Low Temperature Freezing

制冷量 COOLING CAPACITY

型号 Model	项目 Item (W)	Tc/Te	-40°C	-35°C	-30°C	-25°C	-20°C	-15°C	-10°C	-5°C	0°C
WF09KE-TFD-GL1	Q	60°C						3044	3663	4432	5384
	P							2890	3021	3161	3319
	Q	55°C	1265	1677	2080	2509	2998	3580	4290	5161	6228
	P		1989	2159	2305	2434	2554	2672	2796	2934	3094
	Q	50°C	1453	1893	2337	2818	3371	4029	4826	5796	6973
	P		1850	1997	2124	2237	2346	2456	2576	2714	2876
	Q	45°C	1587	2052	2533	3063	3675	4405	5286	6351	7636
	P		1707	1833	1943	2044	2142	2247	2365	2504	2671
	Q	40°C	1683	2170	2684	3258	3928	4726	5686	6844	8232
	P		1564	1672	1767	1856	1947	2048	2166	2308	2483
	Q	35°C	1757	2262	2806	3422	4144	5007	6045	7290	8778
	P		1426	1517	1599	1679	1765	1864	1983	2131	2315
	Q	30°C	1827	2346	2916	3569	4341	5266	6376	7706	9291
	P		1296	1373	1444	1517	1599	1699	1822	1978	2173
	Q	25°C	1907	2437	3029	3717	4535	5517	6697	8109	9786
	P		1179	1244	1306	1374	1455	1557	1686	1851	2059
	Q	20°C	2014	2552	3163	3882	4743	5779	7024	8514	10281
	P		1080	1134	1190	1255	1336	1442	1579	1756	1980
	Q	15°C	2166	2707	3334	4080	4979	6066	7374	8938	
	P		1001	1047	1099	1162	1247	1359	1506	1697	
Q	10°C	2377	2918	3557	4327	5261	6395	7762			
P		949	988	1037	1102	1191	1311	1471			
WF13KE-TFD-GL1	Q	60°C						3844	4626	5596	6799
	P							3649	3814	3992	4192
	Q	55°C	1597	2117	2627	3169	3786	4521	5418	6518	7865
	P		2512	2726	2910	3073	3225	3374	3531	3706	3907
	Q	50°C	1835	2391	2952	3559	4257	5087	6094	7319	8806
	P		2336	2522	2682	2826	2962	3102	3254	3427	3632
	Q	45°C	2004	2592	3199	3868	4641	5563	6675	8021	9643
	P		2155	2315	2454	2581	2705	2837	2986	3162	3373
	Q	40°C	2125	2740	3389	4115	4960	5968	7181	8643	10396
	P		1975	2111	2231	2344	2459	2586	2735	2915	3135
	Q	35°C	2219	2857	3543	4321	5234	6323	7633	9206	11086
	P		1800	1916	2019	2121	2229	2354	2505	2691	2924
	Q	30°C	2307	2963	3682	4508	5483	6650	8052	9732	11733
	P		1637	1734	1824	1916	2020	2145	2301	2497	2744
	Q	25°C	2408	3078	3825	4694	5728	6968	8458	10240	12359
	P		1489	1571	1650	1735	1838	1966	2129	2338	2601
	Q	20°C	2544	3223	3995	4902	5989	7298	8871	10752	12983
	P		1364	1432	1502	1584	1687	1821	1994	2218	2500
	Q	15°C	2735	3418	4210	5152	6288	7660	9312	11287	
	P		1265	1323	1387	1468	1574	1716	1902	2143	
Q	10°C	3002	3685	4492	5464	6644	8076	9803			
P		1198	1248	1309	1391	1504	1656	1858			

注: 1. 测试条件: 回气温度20°C, 过冷度0°C
2. Q--制冷量 (W) P--功率 (W)

Note: 1. Test conditions: R.G. 20°C, subcooling 0°C
2. Q--Capacity(W) P--Power(W)

低温冷冻应用

Low Temperature Freezing

WF

制冷量-R404A

Cooling Capacity - R404A

制冷量 COOLING CAPACITY

型号 Model	项目 Item (W)	Tc/Te	-40°C	-35°C	-30°C	-25°C	-20°C	-15°C	-10°C	-5°C	0°C
WF15KE-TFD-GL1	Q	60°C						5083	6117	7400	8991
	P							4826	5044	5279	5543
	Q	55°C	2112	2800	3474	4190	5007	5979	7164	8619	10400
	P		3321	3605	3848	4064	4264	4462	4670	4900	5166
	Q	50°C	2426	3162	3903	4707	5629	6728	8058	9679	11645
	P		3089	3335	3546	3736	3917	4102	4302	4532	4803
	Q	45°C	2650	3427	4230	5114	6138	7356	8827	10606	12751
	P		2850	3061	3245	3413	3577	3752	3949	4181	4460
	Q	40°C	2810	3624	4482	5441	6559	7892	9496	11429	13747
	P		2611	2792	2950	3100	3252	3420	3617	3854	4146
	Q	35°C	2935	3778	4686	5714	6921	8362	10094	12174	14659
	P		2381	2533	2670	2804	2947	3112	3312	3559	3866
	Q	30°C	3050	3918	4869	5961	7250	8793	10648	12869	15516
	P		2164	2293	2412	2534	2671	2837	3043	3302	3628
	Q	25°C	3184	4070	5059	6208	7574	9214	11184	13542	16343
	P		1969	2077	2182	2295	2430	2599	2816	3091	3439
	Q	20°C	3364	4262	5282	6483	7920	9650	11731	14218	17168
	P		1803	1894	1987	2095	2231	2408	2637	2933	3306
	Q	15°C	3617	4520	5567	6813	8315	10130	12314	14925	
	P		1672	1749	1834	1941	2082	2269	2515	2834	
Q	10°C	3969	4873	5940	7225	8786	10680	12963			
P		1584	1651	1732	1840	1989	2190	2457			
WF18KE-TFD-GL1	Q	60°C						5949	7159	8662	10523
	P							5648	5904	6179	6488
	Q	55°C	2472	3277	4066	4905	5860	6998	8385	10088	12173
	P		3887	4219	4504	4757	4991	5222	5466	5735	6046
	Q	50°C	2840	3701	4568	5509	6588	7874	9432	11328	13629
	P		3615	3903	4151	4373	4585	4801	5036	5304	5621
	Q	45°C	3101	4011	4951	5986	7184	8610	10331	12414	14924
	P		3336	3583	3798	3994	4187	4391	4622	4893	5220
	Q	40°C	3289	4241	5245	6369	7677	9237	11114	13377	16090
	P		3057	3268	3453	3628	3806	4003	4233	4511	4852
	Q	35°C	3435	4422	5484	6688	8100	9787	11814	14249	17158
	P		2786	2965	3126	3282	3450	3643	3877	4166	4525
	Q	30°C	3570	4585	5699	6977	8486	10292	12462	15063	18160
	P		2533	2684	2823	2965	3126	3320	3561	3865	4246
	Q	25°C	3727	4763	5921	7266	8865	10784	13090	15849	19128
	P		2305	2431	2553	2686	2844	3042	3295	3618	4025
	Q	20°C	3937	4988	6183	7588	9270	11295	13730	16641	20094
	P		2110	2216	2325	2452	2611	2818	3087	3432	3870
	Q	15°C	4233	5291	6516	7974	9732	11856	14413	17469	
	P		1957	2047	2147	2272	2437	2656	2944	3316	
Q	10°C	4646	5704	6952	8457	10284	12500	15172			
P		1854	1932	2027	2154	2328	2563	2875			

注: 1. 测试条件: 回气温度20°C, 过冷度0°C
2. Q--制冷量 (W) P--功率 (W)

Note: 1. Test conditions: R.G. 20°C, subcooling 0°C
2. Q--Capacity(W) P--Power(W)

制冷量-R404A

Cooling Capacity - R404A

WF 低温冷冻应用

Low Temperature Freezing

制冷量 COOLING CAPACITY

型号 Model	项目 Item (W)	Tc\Te	-40°C	-35°C	-30°C	-25°C	-20°C	-15°C	-10°C	-5°C	0°C
WF25KE-TFD-GL1	Q	60°C						6497	7818	9459	11491
	P							6168	6447	6747	7085
	Q	55°C	2699	3578	4440	5356	6399	7642	9157	11016	13293
	P		4245	4608	4919	5194	5450	5703	5969	6263	6603
	Q	50°C	3101	4041	4988	6016	7195	8599	10300	12370	14883
	P		3948	4262	4533	4776	5007	5243	5499	5792	6138
	Q	45°C	3387	4380	5406	6537	7845	9402	11281	13556	16297
	P		3643	3913	4147	4362	4572	4796	5047	5344	5701
	Q	40°C	3592	4631	5728	6955	8383	10087	12137	14607	17570
	P		3338	3568	3771	3962	4156	4371	4622	4926	5299
	Q	35°C	3751	4829	5989	7304	8846	10687	12901	15560	18736
	P		3043	3238	3413	3584	3767	3978	4233	4549	4941
	Q	30°C	3899	5007	6223	7619	9266	11239	13609	16449	19831
	P		2766	2931	3083	3238	3414	3625	3889	4221	4637
	Q	25°C	4070	5202	6466	7934	9680	11776	14294	17307	20888
	P		2517	2655	2788	2933	3106	3322	3599	3951	4396
	Q	20°C	4300	5447	6751	8286	10122	12334	14993	18172	21943
	P		2305	2420	2539	2678	2852	3077	3371	3748	4226
	Q	15°C	4622	5778	7115	8708	10627	12947	15739	19076	
	P		2138	2236	2345	2481	2661	2900	3215	3622	
Q	10°C	5073	6229	7592	9235	11230	13650	16568			
P		2025	2110	2213	2352	2542	2799	3140			
WF28KE-TFD-GL1	Q	60°C						7639	9193	11123	13513
	P							7253	7581	7934	8331
	Q	55°C	3174	4208	5221	6298	7525	8986	10767	12954	15631
	P		4992	5418	5784	6108	6409	6706	7019	7365	7764
	Q	50°C	3646	4752	5866	7074	8460	10111	12112	14547	17502
	P		4642	5012	5330	5616	5888	6165	6466	6811	7218
	Q	45°C	3983	5151	6357	7687	9225	11056	13266	15941	19164
	P		4283	4601	4877	5129	5377	5639	5935	6284	6704
	Q	40°C	4224	5446	6736	8178	9858	11861	14272	17177	20661
	P		3925	4196	4434	4658	4887	5140	5436	5793	6231
	Q	35°C	4411	5678	7042	8588	10402	12567	15171	18298	22032
	P		3578	3808	4014	4215	4430	4678	4978	5349	5810
	Q	30°C	4585	5888	7318	8959	10896	13216	16003	19342	23319
	P		3253	3446	3625	3808	4014	4263	4573	4963	5453
	Q	25°C	4786	6117	7603	9330	11383	13848	16809	20352	24563
	P		2960	3122	3279	3449	3652	3907	4232	4646	5169
	Q	20°C	5056	6405	7939	9743	11903	14504	17631	21369	25803
	P		2710	2846	2986	3149	3353	3619	3964	4408	4969
	Q	15°C	5436	6794	8367	10239	12497	15225	18508	22432	
	P		2514	2629	2757	2917	3129	3410	3780	4259	
Q	10°C	5965	7324	8927	10859	13206	16052	19483			
P		2381	2481	2603	2766	2989	3291	3692			

注: 1. 测试条件: 回气温度20°C, 过冷度0°C
2. Q--制冷量 (W) P--功率 (W)

Note: 1. Test conditions: R.G. 20°C, subcooling 0°C
2. Q--Capacity(W) P--Power(W)

低温冷冻应用

Low Temperature Freezing

WF

制冷量-R404A

Cooling Capacity - R404A

制冷量 COOLING CAPACITY

型号 Model	项目 Item (W)	Tc\Te	-40°C	-35°C	-30°C	-25°C	-20°C	-15°C	-10°C	-5°C	0°C
WF34KE-TFD-GL1	Q	60°C						9955	11980	14494	17610
	P							9452	9879	10339	10857
	Q	55°C	4136	5484	6804	8207	9806	11710	14032	16881	20370
	P		6505	7061	7537	7960	8352	8739	9146	9598	10118
	Q	50°C	4752	6193	7644	9218	11025	13176	15783	18956	22807
	P		6050	6532	6946	7318	7672	8034	8427	8876	9407
	Q	45°C	5190	6713	8285	10017	12021	14408	17288	20773	24974
	P		5582	5996	6355	6684	7007	7349	7734	8189	8736
	Q	40°C	5504	7097	8778	10657	12846	15457	18599	22385	26924
	P		5115	5468	5779	6071	6369	6698	7083	7549	8120
	Q	35°C	5748	7400	9177	11192	13555	16377	19770	23844	28712
	P		4663	4962	5230	5492	5773	6096	6487	6971	7572
	Q	30°C	5975	7673	9536	11675	14200	17223	20854	25206	30388
	P		4239	4491	4724	4962	5231	5556	5960	6468	7106
	Q	25°C	6237	7971	9908	12159	14834	18046	21905	26522	32009
	P		3857	4069	4273	4495	4759	5091	5514	6055	6736
	Q	20°C	6589	8347	10346	12697	15512	18901	22975	27847	33626
	P		3531	3709	3891	4103	4370	4716	5166	5744	6476
	Q	15°C	7083	8854	10903	13344	16286	19840	24119	29233	
	P		3276	3426	3593	3802	4077	4444	4927	5550	
Q	10°C	7774	9545	11634	14151	17209	20918	25389			
P		3103	3233	3392	3604	3895	4289	4811			
WF38KE-TFD-GL1	Q	60°C						11477	13811	16710	20302
	P							10897	11390	11920	12516
	Q	55°C	4769	6322	7844	9462	11305	13500	16177	19462	23484
	P		7499	8140	8690	9176	9629	10075	10544	11065	11665
	Q	50°C	5478	7139	8813	10627	12711	15191	18196	21854	26294
	P		6975	7530	8008	8437	8845	9262	9715	10233	10845
	Q	45°C	5983	7739	9551	11548	13859	16610	19931	23949	28792
	P		6435	6913	7327	7706	8078	8472	8917	9440	10071
	Q	40°C	6346	8182	10120	12286	14810	17820	21442	25807	31040
	P		5897	6304	6662	6999	7343	7722	8166	8703	9361
	Q	35°C	6627	8531	10580	12903	15627	18881	22792	27490	33101
	P		5375	5721	6030	6332	6655	7028	7479	8036	8729
	Q	30°C	6888	8846	10994	13459	16370	19855	24042	29059	35034
	P		4887	5177	5446	5721	6031	6405	6871	7457	8192
	Q	25°C	7190	9190	11423	14017	17102	20805	25254	30577	36902
	P		4447	4690	4926	5182	5487	5869	6357	6980	7766
	Q	20°C	7596	9623	11927	14638	17883	21790	26488	32104	38766
	P		4071	4276	4486	4731	5038	5437	5955	6622	7466
	Q	15°C	8166	10207	12570	15383	18775	22873	27806	33701	
	P		3776	3950	4142	4383	4701	5123	5680	6398	
Q	10°C	8962	11004	13412	16315	19840	24116	29270			
P		3578	3727	3910	4155	4490	4945	5547			

注: . 测试条件: 回气温度20°C, 过冷度0°C
2. Q--制冷量 (W) P--功率 (W)

Note: 1. Test conditions: R.G. 20°C, subcooling 0°C
2. Q--Capacity(W) P--Power(W)

制冷量-R404A

Cooling Capacity - R404A

WF 低温冷冻应用

Low Temperature Freezing

制冷量 COOLING CAPACITY

型号 Model	项目 Item (W)	Tc\Te	-40°C	-35°C	-30°C	-25°C	-20°C	-15°C	-10°C	-5°C	0°C
WF49KE-TFD-GL1	Q	60°C						14972	18017	21798	26484
	P							14215	14858	15550	16327
	Q	55°C	6221	8247	10232	12343	14747	17611	21103	25388	30635
	P		9783	10619	11336	11971	12561	13143	13755	14434	15217
	Q	50°C	7146	9313	11497	13864	16581	19816	23737	28509	34300
	P		9098	9823	10446	11006	11539	12082	12673	13349	14147
	Q	45°C	7805	10095	12460	15065	18079	21668	26000	31241	37559
	P		8395	9018	9558	10052	10538	11052	11632	12315	13138
	Q	40°C	8278	10674	13201	16028	19320	23246	27972	33665	40492
	P		7692	8224	8691	9130	9578	10074	10653	11353	12212
	Q	35°C	8645	11129	13802	16832	20386	24630	29733	35860	43180
	P		7012	7462	7866	8260	8681	9168	9756	10484	11388
	Q	30°C	8985	11540	14342	17558	21355	25902	31363	37908	45702
	P		6375	6754	7104	7463	7868	8355	8963	9728	10687
	Q	25°C	9380	11988	14901	18286	22310	27140	32943	39887	48139
	P		5801	6119	6426	6760	7158	7656	8293	9106	10131
	Q	20°C	9909	12553	15559	19096	23329	28425	34553	41879	50570
	P		5311	5578	5852	6171	6572	7092	7769	8638	9739
	Q	15°C	10653	13315	16398	20068	24492	29838	36273	43964	
	P		4926	5152	5404	5718	6132	6683	7409	8347	
Q	10°C	11691	14355	17496	21282	25881	31459	38183			
P		4667	4862	5101	5420	5858	6450	7236			
WF60KE-TWD-GL1	Q	60°C						19550	23526	28463	34581
	P							18561	19401	20304	21320
	Q	55°C	8123	10769	13361	16117	19256	22996	27555	33150	40002
	P		12774	13866	14802	15631	16401	17162	17961	18847	19869
	Q	50°C	9331	12161	15012	18102	21651	25875	30994	37225	44787
	P		11880	12826	13640	14371	15067	15776	16548	17430	18472
	Q	45°C	10192	13182	16269	19671	23606	28293	33949	40793	49043
	P		10961	11775	12480	13125	13760	14431	15188	16080	17155
	Q	40°C	10809	13937	17237	20928	25227	30353	36524	43958	52873
	P		10044	10738	11348	11921	12507	13154	13910	14824	15945
	Q	35°C	11288	14531	18022	21978	26618	32161	38823	46824	56382
	P		9156	9744	10271	10785	11336	11971	12739	13689	14869
	Q	30°C	11732	15068	18727	22926	27885	33821	40952	49498	59675
	P		8324	8819	9276	9745	10273	10910	11703	12702	13955
	Q	25°C	12248	15653	19457	23876	29131	35438	43016	52083	62857
	P		7574	7990	8391	8827	9346	9997	10829	11890	13228
	Q	20°C	12939	16391	20317	24934	30461	37116	45118	54684	66032
	P		6935	7283	7642	8058	8582	9261	10144	11280	12717
	Q	15°C	13910	17386	21411	26203	31981	38961	47363	57405	
	P		6433	6727	7056	7466	8007	8727	9674	10898	
Q	10°C	15266	18744	22845	27789	33794	41077	49857			
P		6094	6349	6660	7077	7649	8423	9448			

注: 1. 测试条件: 回气温度20°C, 过冷度0°C
2. Q--制冷量 (W) P--功率 (W)

Note: 1. Test conditions: R.G. 20°C, subcooling 0°C
2. Q--Capacity(W) P--Power(W)

低温冷冻应用

Low Temperature Freezing

WF

制冷量-R404A

Cooling Capacity - R404A

制冷量 COOLING CAPACITY

型号 Model	项目 Item (W)	Tc\Te	-40°C	-35°C	-30°C	-25°C	-20°C	-15°C	-10°C	-5°C	0°C
WF75KE-TWD-GL1	Q	60°C						24061	28955	35032	42561
	P							22844	23878	24990	26239
	Q	55°C	9997	13254	16444	19836	23700	28303	33913	40800	49233
	P		15722	17065	18217	19238	20186	21122	22106	23197	24455
	Q	50°C	11485	14967	18476	22280	26647	31846	38147	45816	55123
	P		14622	15786	16788	17687	18544	19417	20366	21453	22735
	Q	45°C	12544	16224	20023	24210	29054	34822	41783	50207	60360
	P		13491	14492	15360	16154	16935	17761	18693	19791	21114
	Q	40°C	13304	17154	21215	25758	31049	37358	44952	54102	65074
	P		12362	13217	13967	14672	15393	16189	17120	18245	19625
	Q	35°C	13893	17884	22181	27050	32761	39583	47783	57630	69393
	P		11269	11993	12641	13274	13952	14733	15679	16848	18301
	Q	30°C	14440	18545	23048	28217	34320	41626	50403	60920	73446
	P		10245	10854	11417	11994	12644	13427	14404	15633	17175
	Q	25°C	15074	19265	23947	29386	35853	43616	52942	64102	77362
	P		9322	9833	10327	10864	11503	12304	13328	14633	16281
	Q	20°C	15925	20173	25005	30688	37491	45682	55530	67303	81270
	P		8535	8964	9405	9918	10562	11398	12485	13882	15651
	Q	15°C	17120	21398	26352	32250	39361	47952	58293	70653	
	P		7917	8280	8684	9189	9855	10741	11907	13413	
Q	10°C	18789	23069	28117	34202	41593	50557	61363			
P		7500	7814	8197	8710	9414	10366	11628			

注: 1. 测试条件: 回气温度20°C, 过冷度0°C
2. Q--制冷量 (W) P--功率 (W)

Note: 1. Test conditions: R.G. 20°C, subcooling 0°C
2. Q--Capacity(W) P--Power(W)

外形尺寸

Dimensional information

WB15~WB29

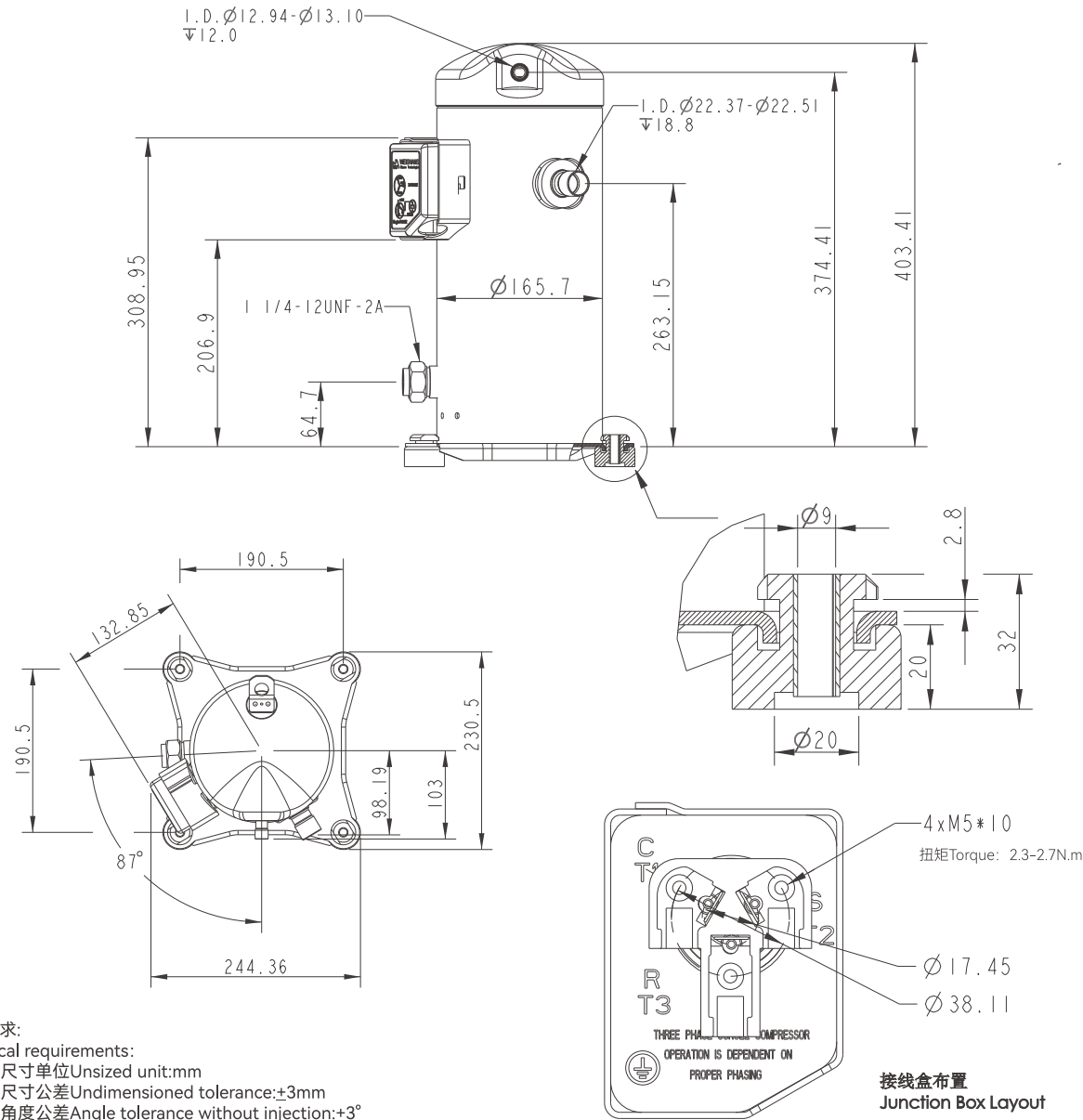

技术要求:
 Technical requirements:
 1. 未注尺寸单位: mm
 2. 未注尺寸公差: ± 3 mm
 3. 未注角度公差: $\pm 3^\circ$

接线盒布置
 Junction Box Layout

外形尺寸

Dimensional information

WB40~WB48

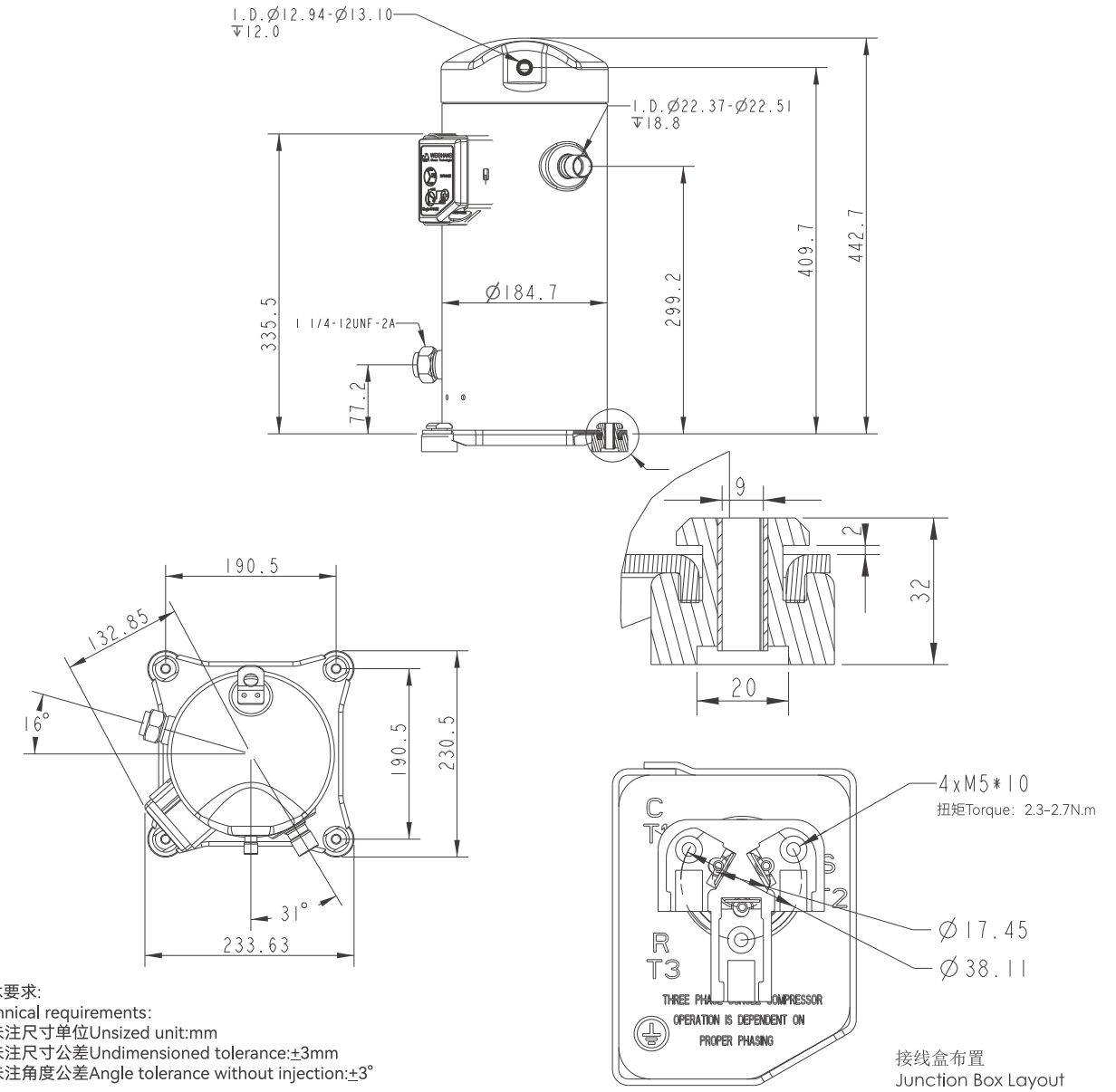

技术要求:
 Technical requirements:
 1. 未注尺寸单位: mm
 2. 未注尺寸公差: ± 3 mm
 3. 未注角度公差: $\pm 3^\circ$

接线盒布置
 Junction Box Layout

外形尺寸 DIMENSIONAL INFORMATION

外形尺寸 DIMENSIONAL INFORMATION

外形尺寸

Dimensional information

WB58~WB110

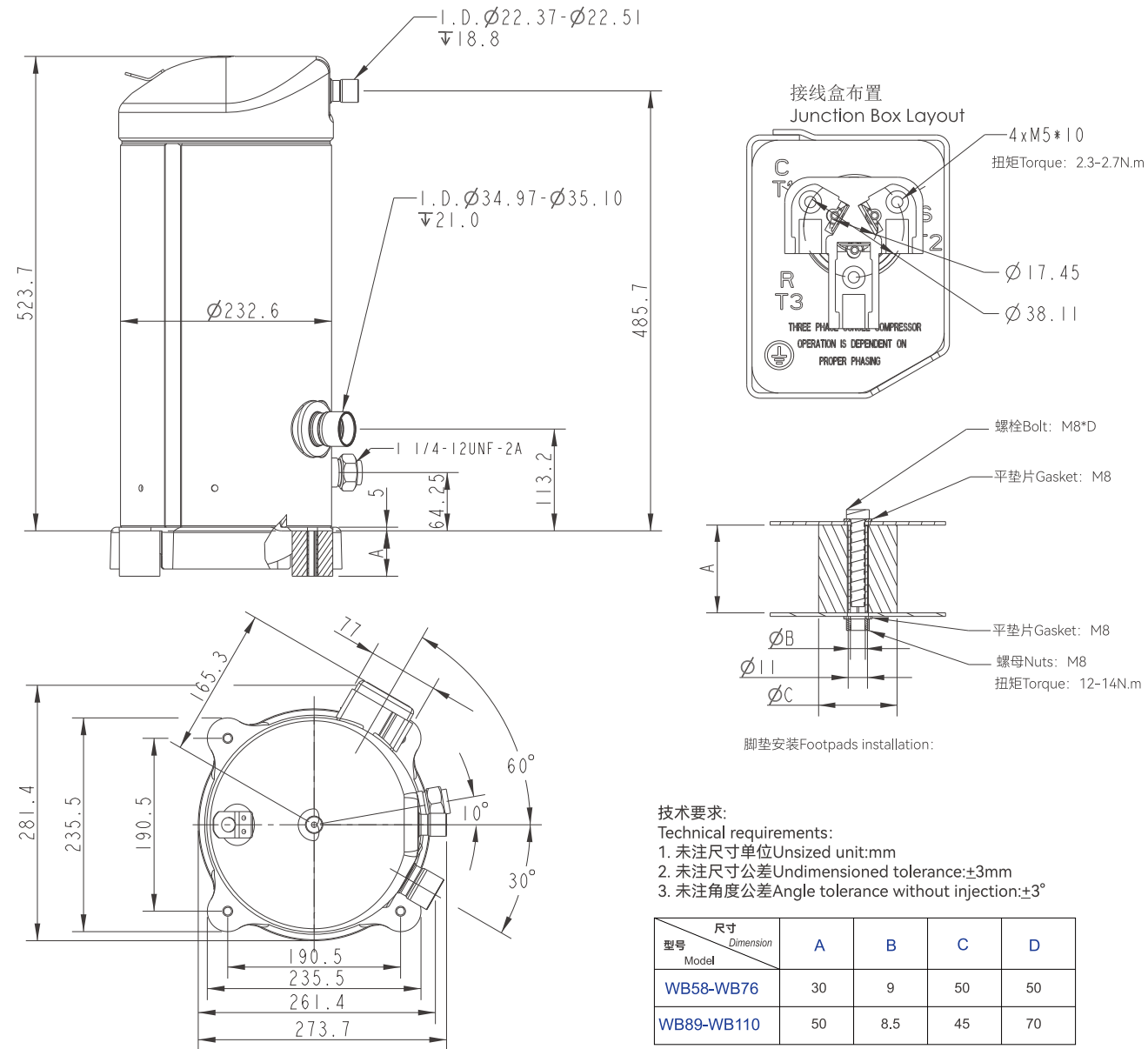

外形尺寸

Dimensional information

WB150~WB190

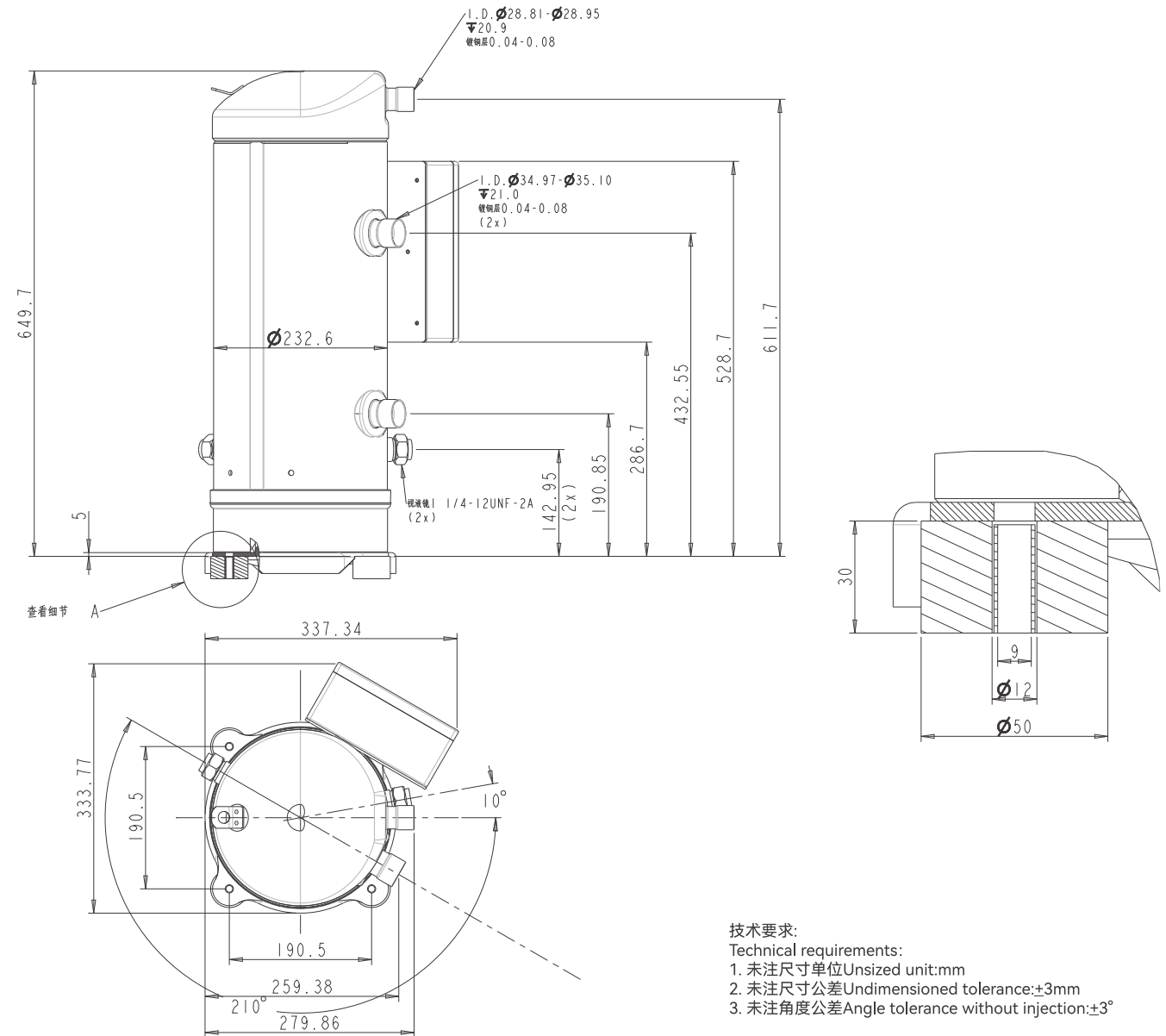

外形尺寸

Dimensional information

WF06~WF13

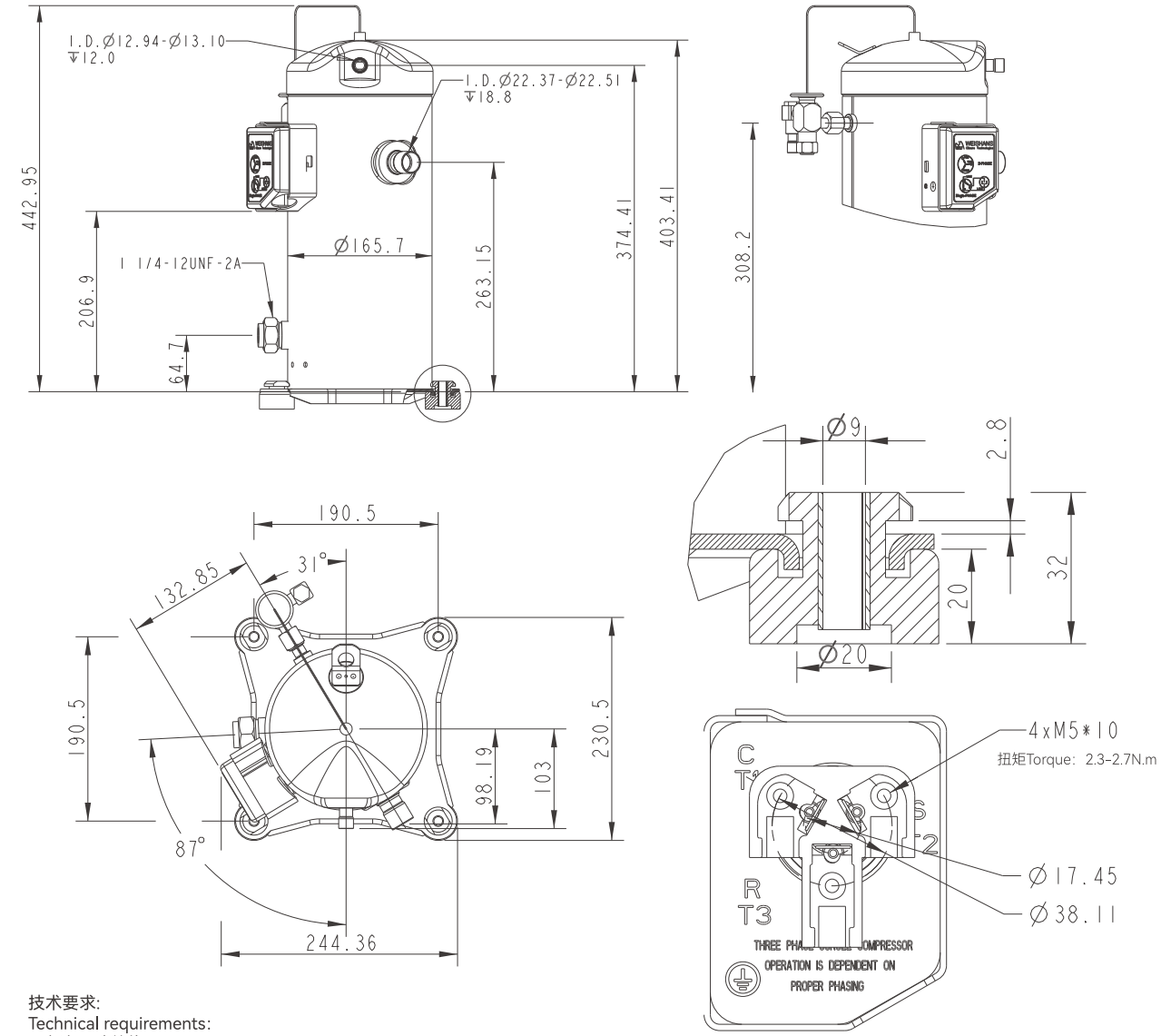

技术要求:
 Technical requirements:
 1.未注尺寸单位Unsize unit:mm
 2.未注尺寸公差Undimensioned tolerance: $\pm 3\text{mm}$
 3.未注角度公差Angle tolerance without injection: $\pm 3^\circ$

接线盒布置
 Junction Box Layout

外形尺寸

Dimensional information

WF15~WF25

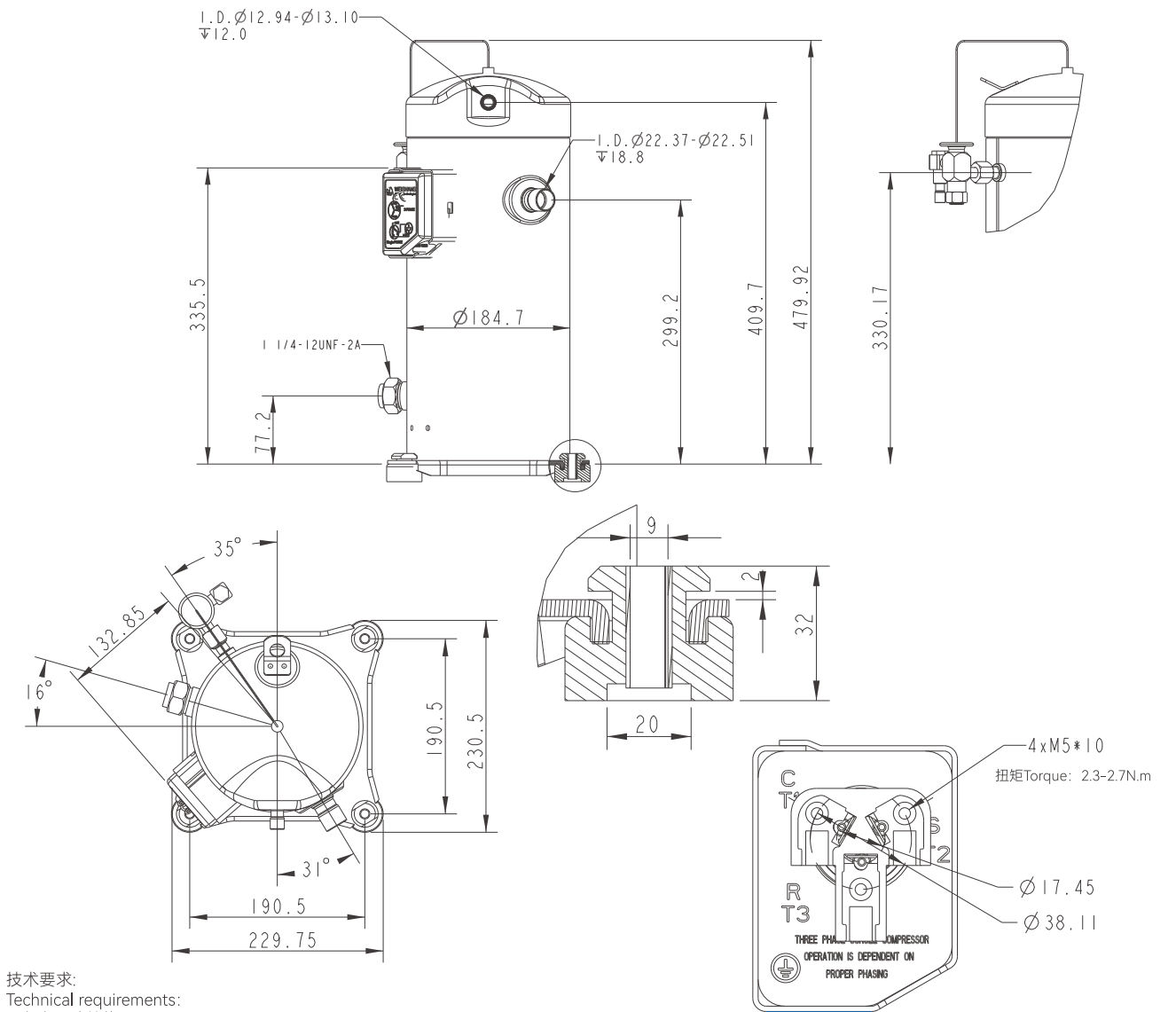

技术要求:
 Technical requirements:
 1.未注尺寸单位Unsize unit:mm
 2.未注尺寸公差Undimensioned tolerance: $\pm 3\text{mm}$
 3.未注角度公差Angle tolerance without injection: $\pm 3^\circ$

接线盒布置
 Junction Box Layout

外形尺寸

Dimensional information

外形尺寸 DIMENSIONAL INFORMATION

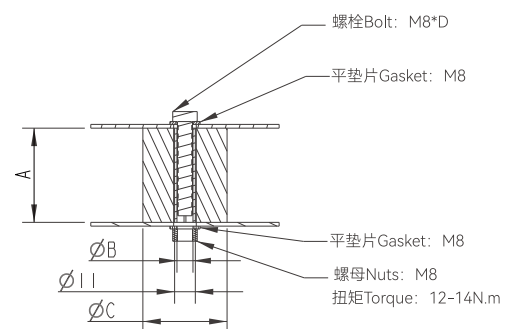
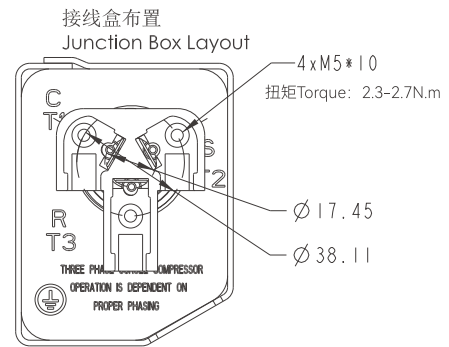
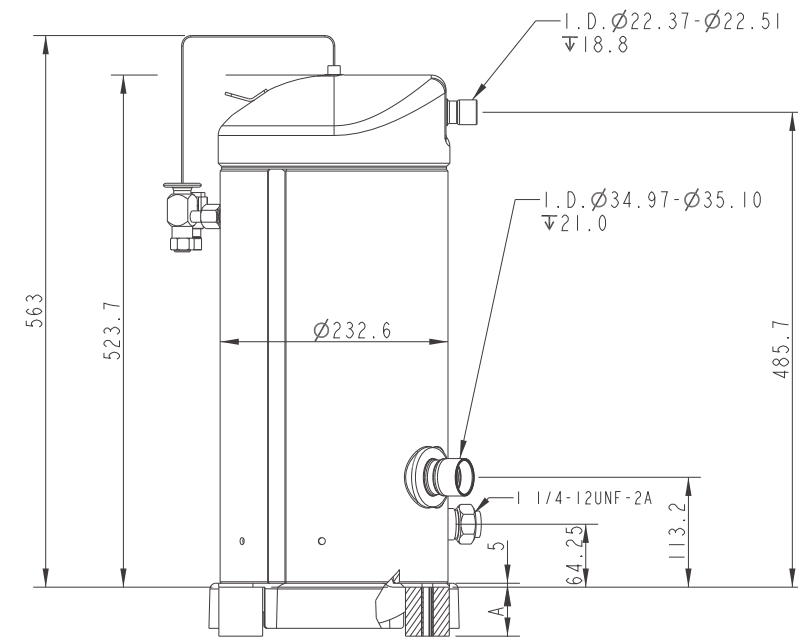

脚垫安装Footpads installation:

技术要求:

Technical requirements:

- 1.未注尺寸单位Unsize unit:mm
- 2.未注尺寸公差Undimensioned tolerance:±3mm
- 3.未注角度公差Angle tolerance without injection:±3°

尺寸 型号 Dimension Model	A	B	C	D
WF28-WF34	30	9	50	50
WF38-WF49	50	8.5	45	70

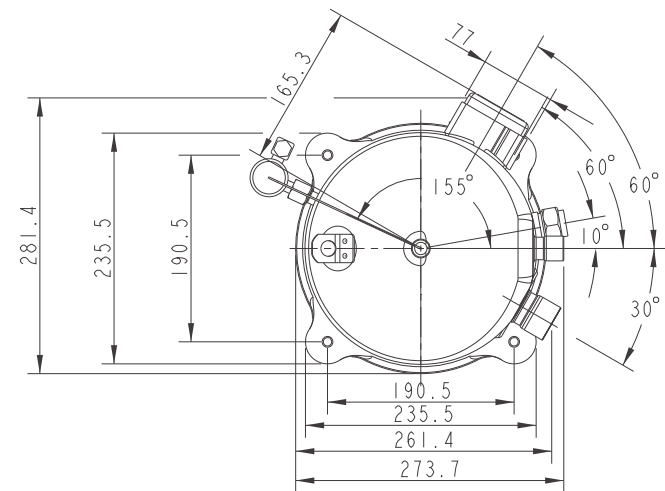

WF28~WF49

外形尺寸

Dimensional information

外形尺寸 DIMENSIONAL INFORMATION

WF60~WF75

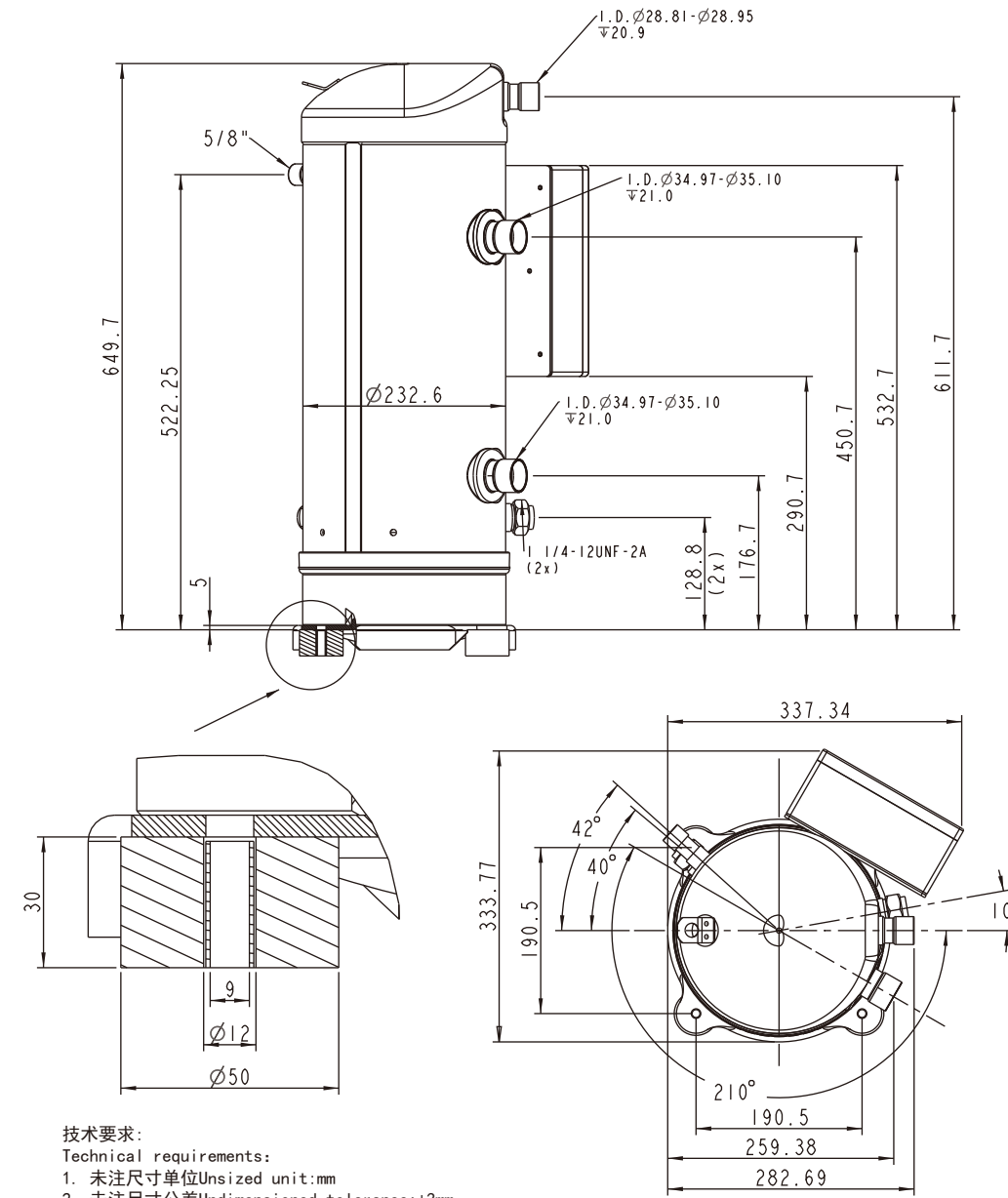

技术要求:

Technical requirements:

- 1.未注尺寸单位Unsize unit:mm
- 2.未注尺寸公差Undimensioned tolerance:±3mm
- 3.未注角度公差Angle tolerance without injection:±3°

